

Product List

SM59R16G6W40PP, SM59R09G6W40PP, SM59R05G6W40PP
SM59R16G6W44JP, SM59R09G6W44JP, SM59R05G6W44JP
SM59R16G6W44QP, SM59R09G6W44QP, SM59R05G6W44QP
SM59R16G6W48VP, SM59R09G6W48VP, SM59R05G6W48VP

Description

The SM59R16G6 is a 1T (one machine cycle per clock) single-chip 8-bit microcontroller. It has 64K-byte embedded Flash for program, and executes all ASM51 instructions fully compatible with MCS-51. SM59R16G6 contains 1KB on-chip RAM, more than 45 GPIOs (LQFP 48), various serial interfaces and many peripheral functions as described below. It can be programmed via writers. Its on-chip ICE is convenient for users in verification during development stage. The high performance of SM59R16G6 can achieve complicated manipulation within short time. About one third of the instructions are pure 1T, and the average speed is 8 times of traditional 8051, the fastest one among all the 1T 51-series. Its excellent EMI and ESD characteristics are advantageous for many different applications.

Ordering Information

SM59R16G6ihhkL yymm

i: process identifier {W = 2.7V ~ 5.5V}

hh: Pin count

k: package type postfix {as table below }

L:PB Free identifier

{No text is Non-PB free , "P" is PB free}

yy: year

mm: month

v: version identifier{ A, B,...}

Postfix	Package	Pin / Pad Configuration
P	40L PDIP	Page 2
J	44L PLCC	Page 3
Q	44L QFP	Page 4
V	48L LQFP	Page 5

Contact SyncMOS : www.syncmos.com.tw
6F, No.10-2 Li- Hsin 1st Road , SBIP, Hsinchu, Taiwan
TEL: 886-3-567-1820 FAX: 886-3-567-1891

Features

- Operating Voltage: 2.7V ~ 5.5V
- High speed architecture of 1 clock/machine cycle (1T), runs up to 25MHz
- 1T/2T can be switched on the fly by SFR
- Instruction-set compatible with MCS-51
- 64K/36K/20KBytes on-chip program memory.
- External RAM addresses up to 64K bytes. Standard 12T interface for external RAM access.
- 256 bytes RAM as standard 8052, plus 1K bytes on-chip expandable RAM
- Dual 16-bit Data Pointers (DPTR0 & DPTR1)
- One serial peripheral interfaces in full duplex mode (UART0), Additional Baud Rate Generator for Serial 0.
- Three 16-bit Timers/Counters. (Timer 0 , 1, 2)
- 37 GPIOs(PDIP 40) · 41 GPIOs(PLCC 44/PQFP 44) · 45 GPIOs(LQFP 48),GPIOs can select four Type(quasi-bidirectional 、 push-pull 、 open drain 、 input-only) · default is quasi-bidirectional(pull-up)
- External interrupt 0,1 with four priority levels
- Programmable watchdog timer (WDT)
- One IIC interface (Master/Slave mode)
- One SPI interface (Master/Slave mode)
- 4-channel PWM on port 2 or port 4 (default)
- 4-channel 16-bit compare /capture /load functions
- 22.1184MHz Internal RC oscillator, with programmable clock divider
- Configurable Oscillator pin
- ISP/IAP/ICP functions.
- ISP service program space configurable in N*256 byte (N=0 to 16) size.
- EEPROM function
- On-chip in-circuit emulator (ICE) function with On-Chip Debugger (OCD)
- ALE output select.
- LVI/LVR ±5% (LVR deglitch 500ns)
- Enhanced user code protection
- Power management unit for idle and power down modes

Specifications subject to change without notice contact your sales representatives for the most recent information.



Pin Configuration

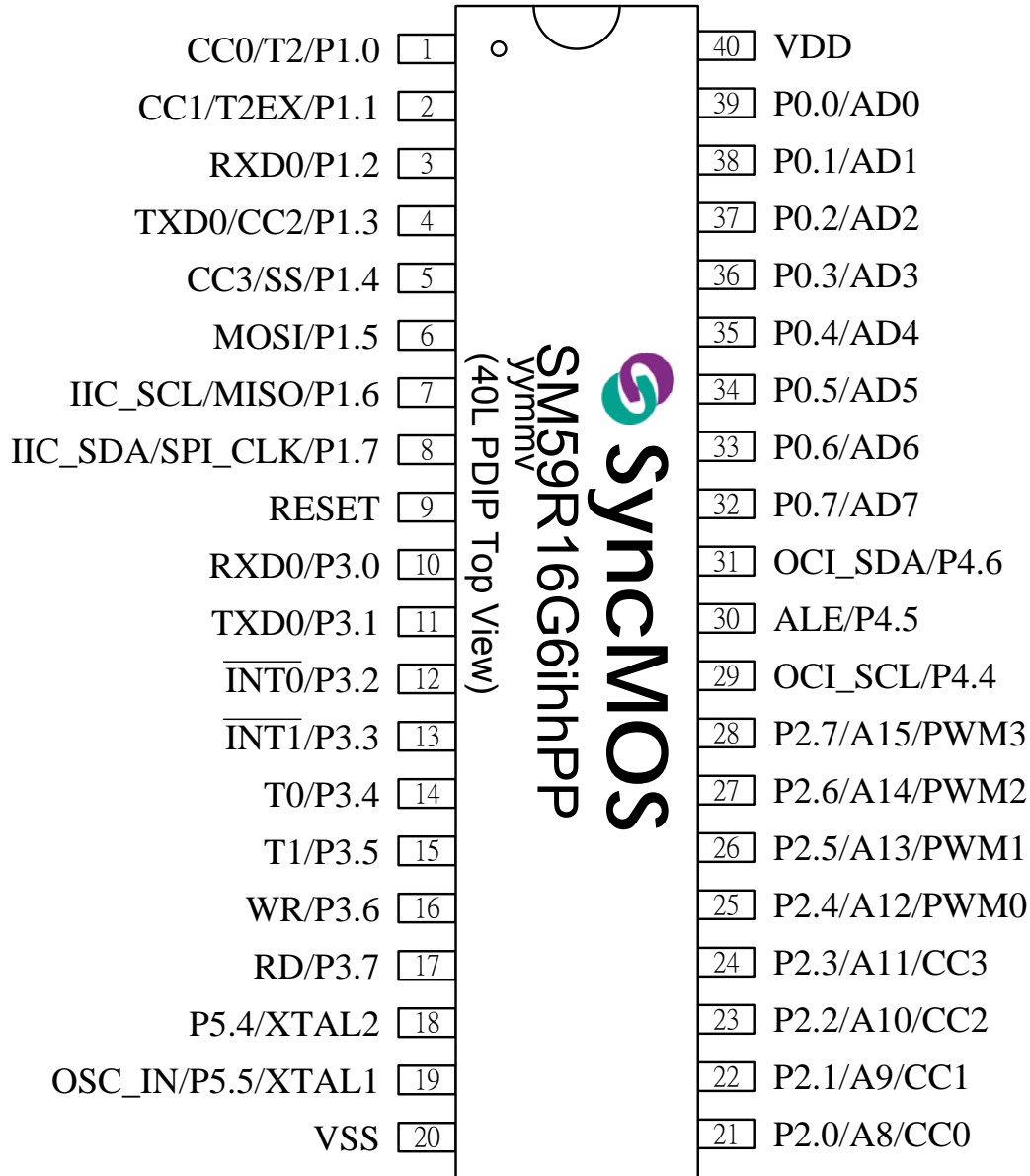

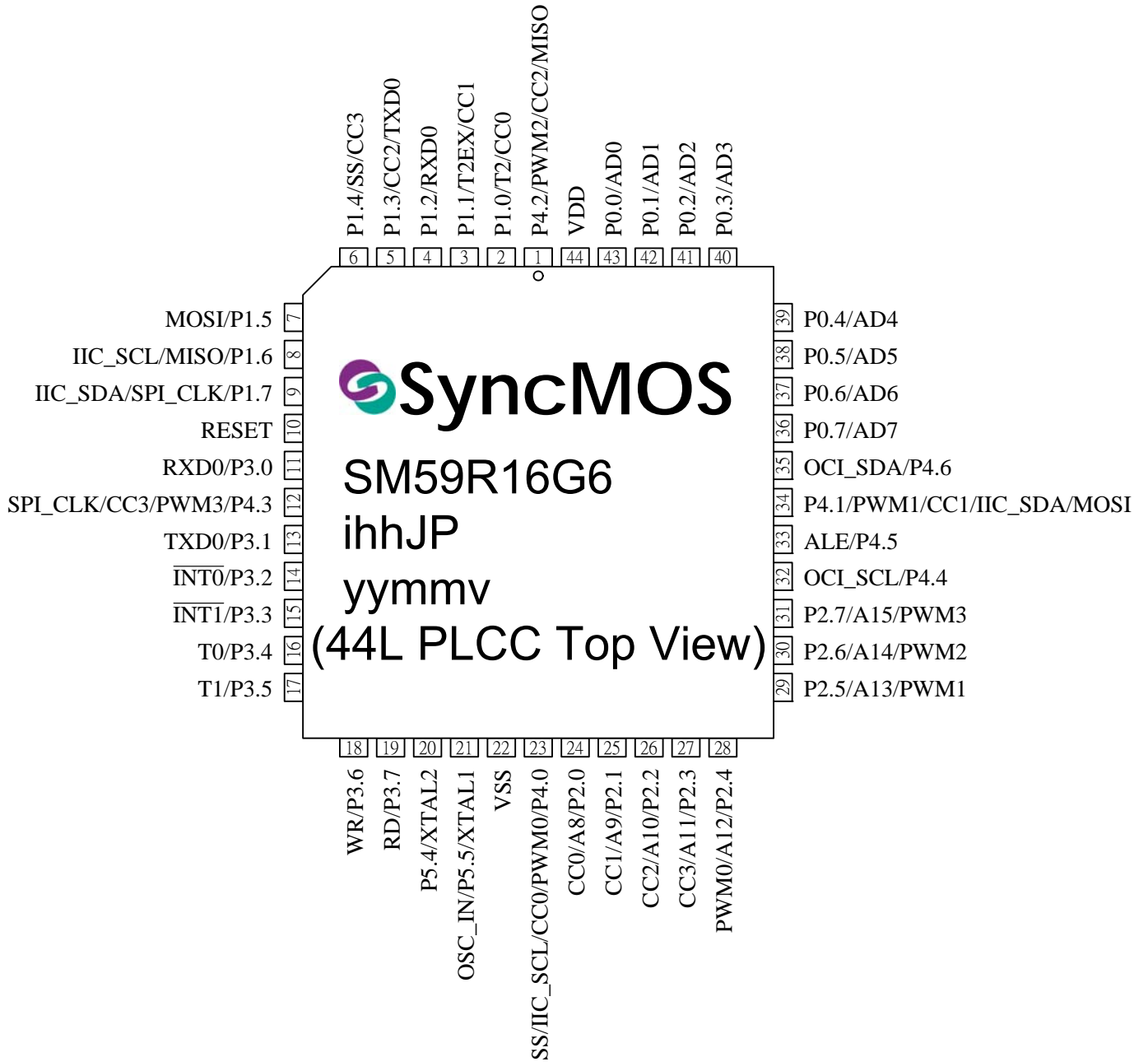

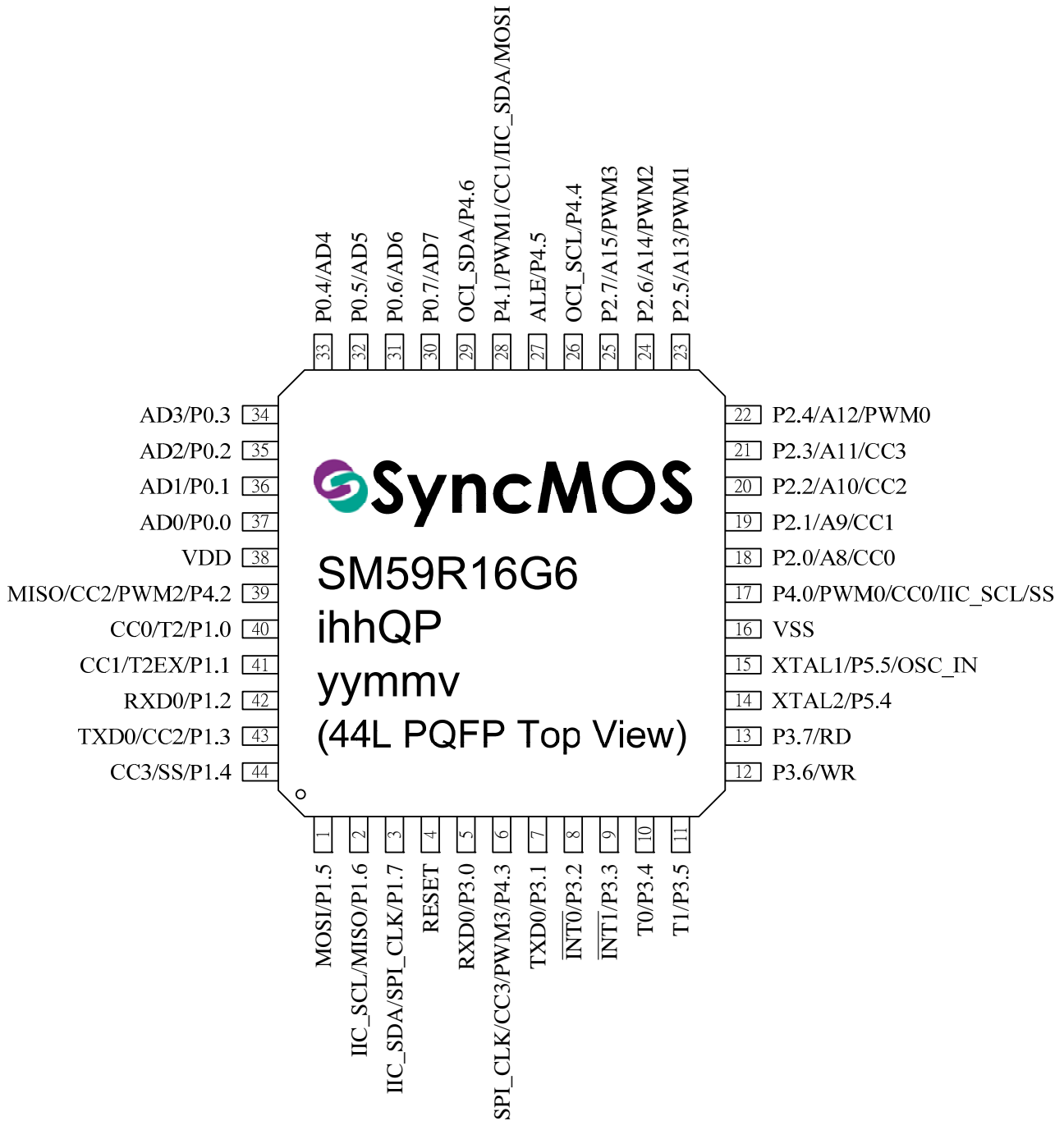

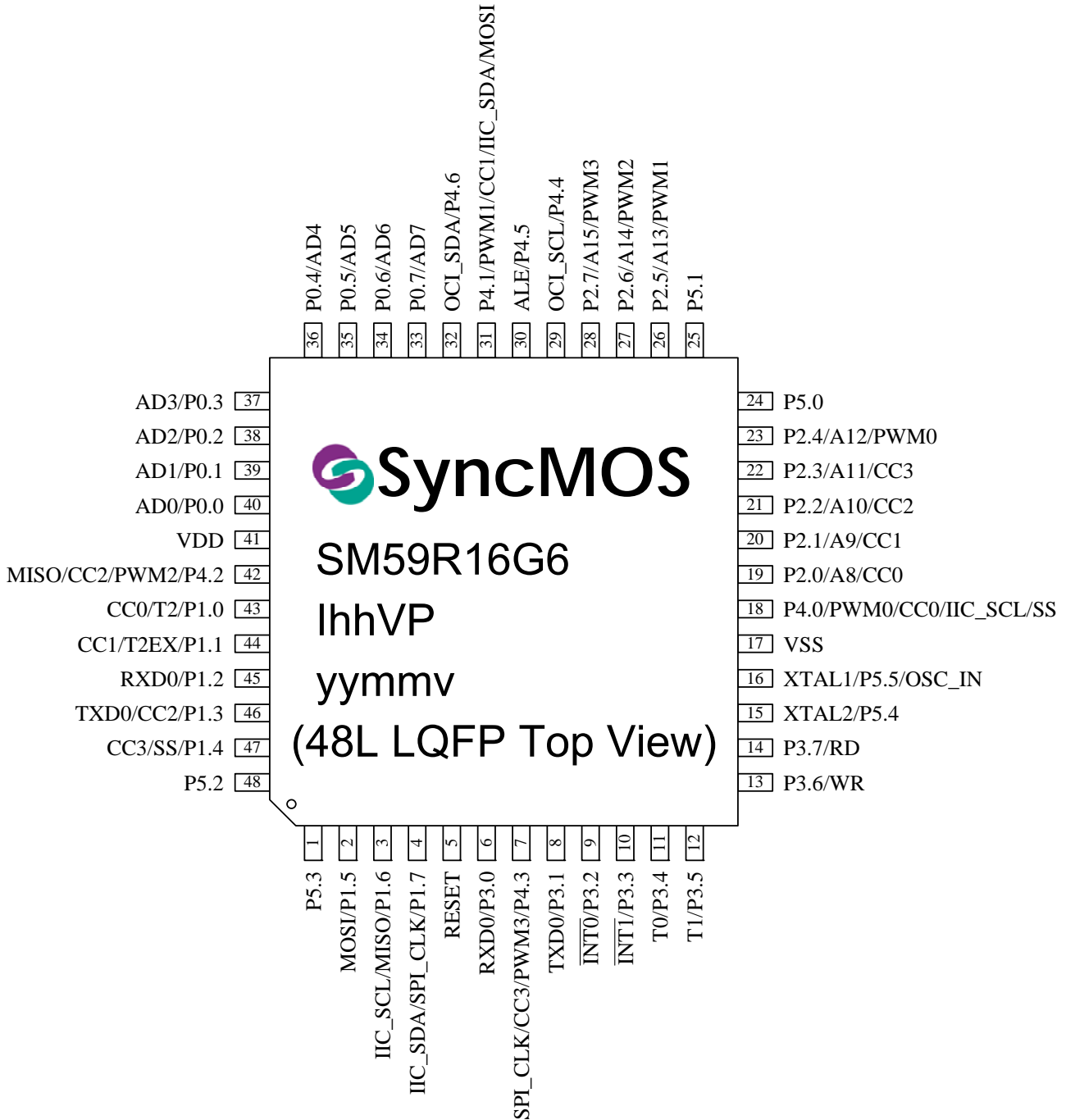



Block Diagram

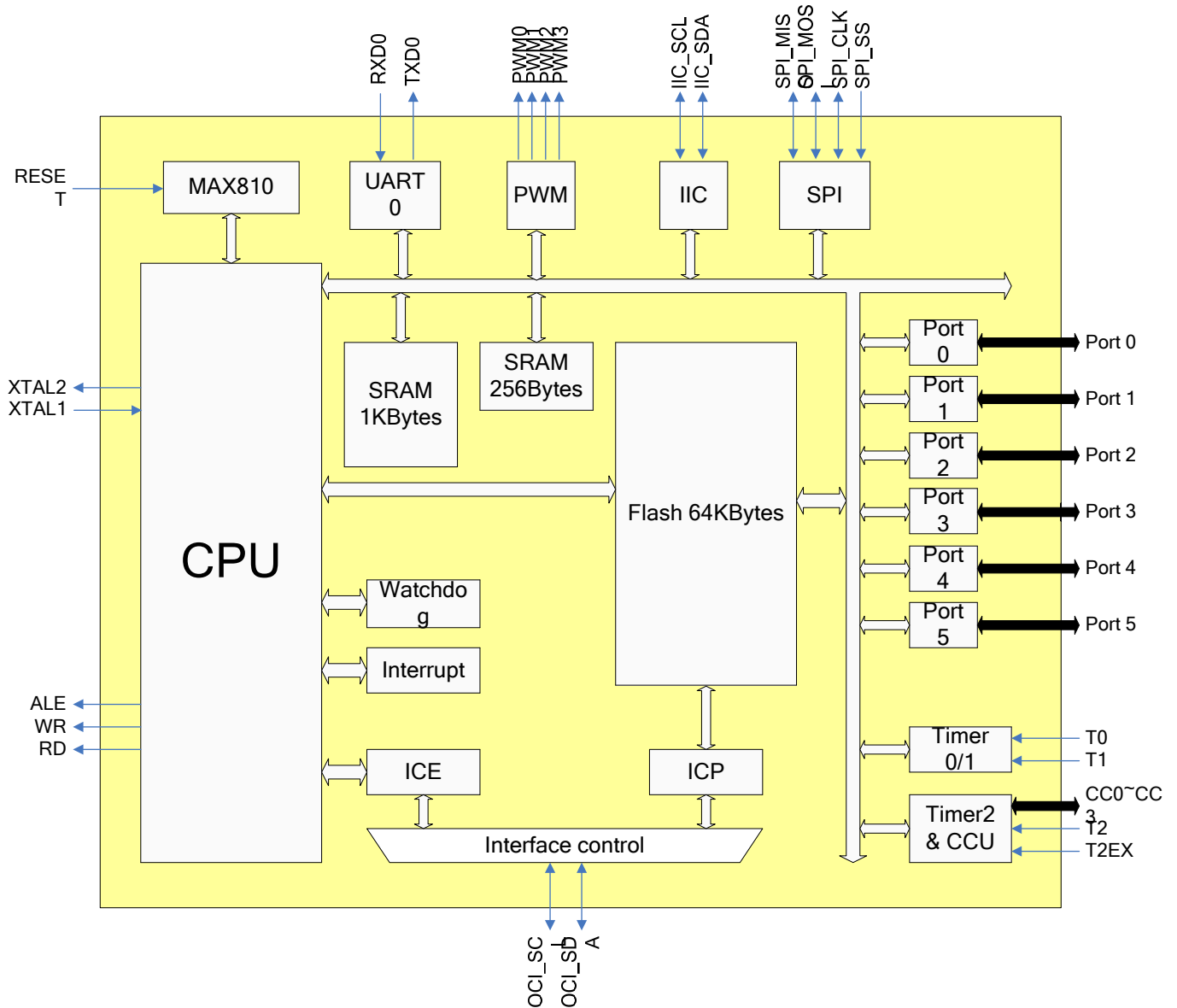



Pin Description

40L PDIP	44L PLCC	44L PQFP	48L LQFP	Symbol	I/O	Description
	1	39	42	P4.2/PWM2/CC2/ MISO	I/O	Bit 2 of port 4 & PWM Channel 2 & Timer 2 compare/capture Channel 2 & SPI interface Serial Data Master Input or Slave Output pin
1	2	40	43	P1.0/T2/CC0	I/O	Bit 0 of port 1 & Timer 2 external input clock & Timer 2 compare/capture Channel 0
2	3	41	44	P1.1/T2EX/CC1	I/O	Bit 1 of port 1 & Timer 2 capture trigger & Timer 2 compare/capture Channel 1
3	4	42	45	P1.2/RXD0	I/O	Bit 2 of port 1 & Serial interface channel 0 receive data
4	5	43	46	P1.3/TXD0/CC2	I/O	Bit 3 of port 1 & Serial interface channel 0 transmit data or receive clock in mode 0 & Timer 2 compare/capture Channel 2
5	6	44	47	P1.4/SS/CC3	I/O	Bit 4 of port 1 & SPI interface Slave Select pin & Timer 2 compare/capture Channel 3
			48	P5.2	I/O	Bit 2 of port 5
			1	P5.3	I/O	Bit 3 of port 5
6	7	1	2	P1.5/MOSI	I/O	Bit 5 of port 1 & SPI interface Serial Data Master Output or Slave Input pin
7	8	2	3	P1.6/MISO/ IIC_SCL	I/O	Bit 6 of port 1 & SPI interface Serial Data Master Input or Slave Output pin & IIC SCL pin
8	9	3	4	P1.7/SPI_CLK/ IIC_SDA	I/O	Bit 7 of port 1 & SPI interface Clock pin & IIC SDA pin
9	10	4	5	RESET	I/O	Reset pin
10	11	5	6	P3.0/RXD0	I/O	Bit 0 of port 3 & Serial interface channel 0 receive/transmit data
	12	6	7	P4.3/PWM3/CC3/ SPI_CLK	I/O	Bit 3 of port 4 & PWM Channel 3 & Timer 2 compare/capture Channel 3 & SPI interface Clock pin
11	13	7	8	P3.1/TXD0	I/O	Bit 1 of port 3 & Serial interface channel 0 transmit data or receive clock in mode 0
12	14	8	9	P3.2/#INT0	I/O	Bit 2 of port 3 & External interrupt 0
13	15	9	10	P3.3/#INT1	I/O	Bit 3 of port 3 & External interrupt 1
14	16	10	11	P3.4/T0	I/O	Bit 4 of port 3 & Timer 0 external input
15	17	11	12	P3.5/T1	I/O	Bit 5 of port 3 & Timer 1 external input
16	18	12	13	P3.6/#WR	I/O	Bit 6 of port 3 & external memory write signal
17	19	13	14	P3.7/#RD	I/O	Bit 7 of port 3 & external memory read signal
18	20	14	15	XTAL2/P5.4	O	Crystal output & bit4 of port 5
19	21	15	16	XTAL1/P5.5/ OSC_IN	I	Crystal input & bit5 of port 5 & Oscillator input
20	22	16	17	VSS	I	Power supply
	23	17	18	P4.0/PWM0/CC0/ IIC_SCL/SS	I/O	Bit 0 of port 4 & PWM Channel 0 & Timer 2 compare/capture Channel 0 & IIC SCL pin & SPI interface Slave Select pin
21	24	18	19	P2.0 /A8/CC0	I/O	Bit 0 of port 2 & Bit 8 of external memory address & Timer 2 compare/capture Channel 0
22	25	19	20	P2.1 /A9/CC1	I/O	Bit 1 of port 2 & Bit 9 of external memory address & Timer 2 compare/capture Channel 1
23	26	20	21	P2.2/A10/CC2	I/O	Bit 2 of port 2 & Bit 10 of external memory address & Timer 2 compare/capture Channel 2
24	27	21	22	P2.3/A11/CC3	I/O	Bit 3 of port 2 & Bit 11 of external memory address & Timer 2 compare/capture Channel 3
25	28	22	23	P2.4/A12/PWM0	I/O	Bit 4 of port 2 & Bit 12 of external memory address & PWM Channel 0

Specifications subject to change without notice contact your sales representatives for the most recent information.



40L PDIP	44L PLCC	44L QFP	48L LQFP	Symbol	I/O	Description
			24	P5.0	I/O	Bit 0 of port 5
			25	P5.1	I/O	Bit 1 of port 5
26	29	23	26	P2.5/A13/PWM1	I/O	Bit 5 of port 2 & Bit 13 of external memory address & PWM Channel 1
27	30	24	27	P2.6/A14/PWM2	I/O	Bit 6 of port 2 & Bit 14 of external memory address & PWM Channel 2
28	31	25	28	P2.7/A15/PWM3	I/O	Bit 7 of port 2 & Bit 15 of external memory address & PWM Channel 3
29	32	26	29	OCI_SCL/P4.4	I/O	On-Chip Instrumentation Clock I/O pin of ICE and ICP functions & Bit 4 of port 4
30	33	27	30	ALE/P4.5	I/O	Address latch enable & Bit 5 of port 4
	34	28	31	P4.1/PWM1/CC1/ IIC_SDA/MOSI	I/O	Bit 1 of port 4 & PWM Channel 1 & Timer 2 compare/capture Channel 1 & IIC SDA pin & SPI interface Serial Data Master Output or Slave Input pin
31	35	29	32	OCI_SDA/P4.6	I/O	On-Chip Instrumentation Command and data I/O pin synchronous to OCI_SCL in ICE and ICP functions & Bit 6 of port 4
32	36	30	33	P0.7/AD7	I/O	Bit 7 of port 0 & Bit 7 of external memory address/ data
33	37	31	34	P0.6/AD6	I/O	Bit 6 of port 0 & Bit 6 of external memory address/ data
34	38	32	35	P0.5/AD5	I/O	Bit 5 of port 0 & Bit 5 of external memory address/ data
35	39	33	36	P0.4/AD4	I/O	Bit 4 of port 0 & Bit 4 of external memory address/ data
36	40	34	37	P0.3/AD3	I/O	Bit 3 of port 0 & Bit 3 of external memory address/ data
37	41	35	38	P0.2/AD2	I/O	Bit 2 of port 0 & Bit 2 of external memory address/ data
38	42	36	39	P0.1/AD1	I/O	Bit 1 of port 0 & Bit 1 of external memory address/ data
39	43	37	40	P0.0/AD0	I/O	Bit 0 of port 0 & Bit 0 of external memory address/ data
40	44	38	41	VDD	I	Power supply



Special Function Register (SFR)

A map of the Special Function Registers is shown as below:

Hex\Bin	X000	X001	X010	X011	X100	X101	X110	X111	Bin/Hex
F8	IICS	IICCTL	IICA1	IICA2	IICRWD	IICS2			FF
F0	B	SPIC1	SPIC2	SPITXD	SPIRXD	SPIS		TAKEY	F7
E8	P4								EF
E0	ACC	ISPF AH	ISPF AL	ISPF D	ISPF C	ISPST	LVC	SWRES	E7
D8	P5	PFC ON	P3M0	P3M1	P4M0	P4M1	P5M0	P5M1	DF
D0	PSW	CCEN2	P0M0	P0M1	P1M0	P1M1	P2M0	P2M1	D7
C8	T2CON	CCCON	CRCL	CRCH	TL2	TH2	PWMMDH	PWMMDL	CF
C0	IRCON	CCEN	CCL1	CCH1	CCL2	CCH2	CCL3	CCH3	C7
B8	IEN1	IP1	S0RELH		PWMD0H	PWMD0L	PWMD1H	PWMD1L	BF
B0	P3	PWMD2H	PWMD2L	PWMD3H	PWMD3L	PWMC	WDTC	WDTK	B7
A8	IEN0	IP0	S0RELL						AF
A0	P2	RSTS							A7
98	S0CON	S0BUF							9F
90	P1	AUX	AUX2						97
88	TCON	TMOD	TL0	TL1	TH0	TH1		IFCON	8F
80	P0	SP	DPL	DPH	DPL1	DPH1	RCON	PCON	87
Hex\Bin	X000	X001	X010	X011	X100	X101	X110	X111	Bin/Hex

Note: Special Function Registers reset values and description for SM59R16G6

Register	Location	Reset value	Description
P0	80H	FFH	Port 0
SP	81H	07H	Stack Pointer
DPL	82H	00H	Data Pointer 0 low byte
DPH	83H	00H	Data Pointer 0 high byte
DPL1	84H	00H	Data Pointer 1 low byte
DPH1	85H	00H	Data Pointer 1 high byte
RCON	86H	00H	Internal RAM control register
PCON	87H	40H	Power Control
TCON	88H	00H	Timer/Counter Control
TMOD	89H	00H	Timer Mode Control
TL0	8AH	00H	Timer 0, low byte
TL1	8BH	00H	Timer 1, low byte
TH0	8CH	00H	Timer 0, high byte
TH1	8DH	00H	Timer 1, high byte
IFCON	8FH	00H	Interface control register
P1	90H	FFH	Port 1

Specifications subject to change without notice contact your sales representatives for the most recent information.



Register	Location	Reset value	Description
AUX	91H	00H	Auxiliary register
AUX2	92H	00H	Auxiliary register 2
S0CON	98H	00H	Serial Port 0, Control Register
S0BUF	99H	00H	Serial Port 0, Data Buffer
P2	A0H	FFH	Port 2
RSTS	A1H	00H	Reset Status Flag Register
IEN0	A8H	00H	Interrupt Enable Register 0
IP0	A9H	00H	Interrupt Priority Register 0
S0RELL	AAH	00H	Serial Port 0, Reload Register, low byte
P3	B0H	FFH	Port 3
PWMD2H	B1H	00H	PWM channel 2 data high byte
PWMD2L	B2H	00H	PWM channel 2 data low byte
PWMD3H	B3H	00H	PWM channel 3 data high byte
PWMD3L	B4H	00H	PWM channel 3 data low byte
PWMC	B5H	00H	PWM control register
WDTC	B6H	04H	Watchdog timer control register
WDTK	B7H	00H	Watchdog timer refresh key.
IEN1	B8H	00H	Interrupt Enable Register 1
IP1	B9H	00H	Interrupt Priority Register 1
S0RELH	BAH	00H	Serial Port 0, Reload Register, high byte
PWMD0H	BCH	00H	PWM channel 0 data high byte
PWMD0L	BDH	00H	PWM channel 0 data low byte
PWMD1H	BEH	00H	PWM channel 1 data high byte
PWMD1L	BFH	00H	PWM channel 1 data low byte
IRCON	C0H	00H	Interrupt Request Control Register
CCEN	C1H	00H	Compare/Capture Enable Register
CCL1	C2H	00H	Compare/Capture Register 1, low byte
CCH1	C3H	00H	Compare/Capture Register 1, high byte
CCL2	C4H	00H	Compare/Capture Register 2, low byte
CCH2	C5H	00H	Compare/Capture Register 2, High byte
CCL3	C6H	00H	Compare/Capture Register 3, low byte
CCH3	C7H	00H	Compare/Capture Register 3, high byte
T2CON	C8H	00H	Timer 2 Control
CCCON	C9H	00H	Compare/Capture Control
CRCL	CAH	00H	Compare/Reload/Capture Register, low byte
CRCH	CBH	00H	Compare/Reload/Capture Register, high byte
TL2	CCH	00H	Timer 2, low byte
TH2	CDH	00H	Timer 2, high byte
PWMMDH	CEH	00H	PWM Max Data Register, high byte.
PWMMDL	CFH	FFH	PWM Max Data Register, low byte.
PSW	D0H	00H	Program Status Word
CCEN2	D1H	00H	Compare/Capture Enable 2 register

Specifications subject to change without notice contact your sales representatives for the most recent information.



Register	Location	Reset value	Description
P0M0	D2H	00H	Port 0 output mode 0
P0M1	D3H	00H	Port 0 output mode 1
P1M0	D4H	00H	Port 1 output mode 0
P1M1	D5H	00H	Port 1 output mode 1
P2M0	D6H	00H	Port 2 output mode 0
P2M1	D7H	00H	Port 2 output mode 1
P5	D8H	3FH	Port 5
PFCON	D9H	00H	Peripheral Frequency control register
P3M0	DAH	00H	Port 3 output mode 0
P3M1	DBH	00H	Port 3 output mode 1
P4M0	DCH	00H	Port 4 output mode 0
P4M1	DDH	00H	Port 4 output mode 1
P5M0	DEH	00H	Port 5 output mode 0
P5M1	DFH	00H	Port 5 output mode 1
ACC	E0H	00H	Accumulator
ISPF AH	E1H	FFH	ISP Flash Address-High register
ISPF AL	E2H	FFH	ISP Flash Address-Low register
ISPF D	E3H	FFH	ISP Flash Data register
ISPF C	E4H	00H	ISP Flash control register
ISPF S	E5H	00H	ISP Flash status
LVC	E6H	20H	Low voltage control register
SWRES	E7H	00H	Software Reset register
P4	E8H	FFH	Port 4
B	F0H	00H	B Register
SPIC1	F1H	08H	SPI control register 1
SPIC2	F2H	00H	SPI control register 2
SPITXD	F3H	00H	SPI transmit data buffer
SPIRXD	F4H	00H	SPI receive data buffer
SPIS	F5H	40H	SPI status register
TAKEY	F7H	00H	Time Access Key register
IICS	F8H	00H	IIC status register
IICCTL	F9H	04H	IIC control register
IICA1	FAH	A0H	IIC channel 1 Address 1 register
IICA2	FBH	60H	IIC channel 1 Address 2 register
IICRWD	FCH	00H	IIC channel 1 Read / Write Data buffer
IICS2	FDH	00H	IIC status2 register



Function Description

1 General Features

SM59R16G6 is an 8-bit micro-controller. All of its functions and the detailed meanings of SFR will be given in the following sections.

1.1 Embedded Flash

The program can be loaded into the embedded 64KB/36KB/20KB Flash memory via its writer or In-System Programming (ISP). The high-quality Flash has a 100K-write cycle life, suitable for re-programming and data recording as EEPROM.

1.2 IO Pads

The SM59R16G6 has six I/O ports: Port 0, Port 1, Port 2, Port 3, Port 4, and Port 5. Ports 0, 1, 2, 3 are 8-bit ports, Port 4 is a 7-bit port and Port 5 is a 6-bit port. These are: quasi-bidirectional (standard 8051 port outputs), push-pull, open drain, and input-only. As description in section 5.

The OCI_SCL, ALE and OCI_SDA can be define as P4.4, P4.5 and P4.6 by writer or ISP.

The XTAL2 and XTAL1 can define as P5.4 and P5.5 by writer or ISP, when user use internal OSC as system clock; when user use external OSC as system clock and input into XTAL1, Only XTAL2 can be defined as P5.4.

All the pads for P0 ~ P5 are with slew rate to reduce EMI. The other way to reduce EMI is to disable the ALE output if unused. This is selected by its SFR. The IO pads can withstand 4KV ESD in human body mode guaranteeing the SM59R16G6's quality in high electro-static environments.

1.3 2T/1T Selection

The conventional 52-series MCUs are 12T, i.e., 12 oscillator clocks per machine cycle. SM59R16G6 is a 2T or 1T MCU, i.e., its machine cycle is two-clock or one-clock. In the other words, it can execute one instruction within two clocks or only one clock. The difference between 2T mode and 1T mode are given in the example in Fig. 1-1.

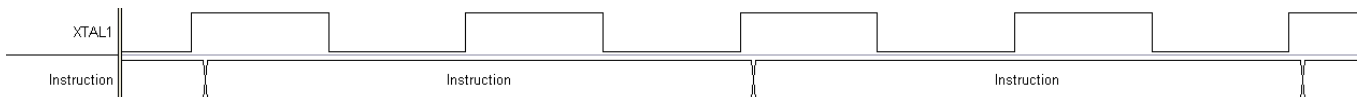

Fig. 1-1(a): The waveform of internal instruction signal in 2T mode

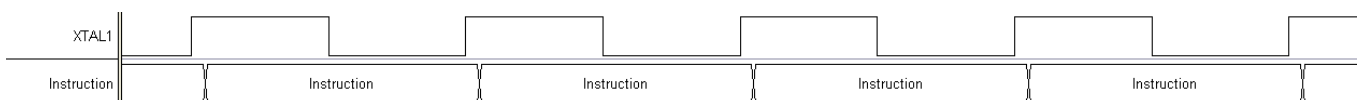

Fig. 1-1(b): The waveform of internal instruction signal in 1T mode



The default is in 2T mode, and it can be changed to 1T mode if IFCON [7] (at address 8Fh) is set to high any time. Not every instruction can be executed with one machine cycle. The exact machine cycle number for all the instructions are given in the next section.

1.4 RESET

1.4.1 Hardware RESET function

SM59R16G6 provides Internal reset circuit inside, the Internal reset time can set by writer or ISP.

Internal Reset time
25ms (default)
200ms
100ms
50ms
16ms
8ms
4ms

1.4.2 Software RESET function

SM59R16G6 provides one software reset mechanism to reset whole chip. To perform a software reset, the firmware must write three specific values 55H, AAH and 5AH sequentially to the TAKEY register to enable the Software Reset register (SWRES) write attribute. After SWRES register obtain the write authority, the firmware can write FFh to the SWRES register. The hardware will decode a reset signal that "OR" with the other hardware reset. The SWRES register is self-reset at the end of the software reset procedure.

Mnemonic	Description	Direct	Bit 7	Bit 6	Bit 5	Bit 4	Bit 3	Bit 2	Bit 1	Bit 0	RESET
Software Reset function											
TAKEY	Time Access Key register	F7H	TAKEY [7:0]								00H
SWRES	Software Reset register	E7H	SWRES [7:0]								00H
RSTS	Reset Status Flag register	A1h	-	-	-	PDRF	WDTF	SWRF	LVRF	PORF	00H

1.4.3 Time Access Key register (TAKEY)

Mnemonic: TAKEY	Address: F7H
<div style="display: flex; justify-content: space-around; font-size: small;"> 76543210Reset </div> <div style="border: 1px solid black; padding: 5px; display: flex; justify-content: space-between;"> TAKEY [7:0] 00H </div>	

Software reset register (SWRES) is read-only by default; software must write three specific values 55H, AAH and 5AH sequentially to the TAKEY register to enable the SWRES register write attribute. That is:

```
MOV TAKEY, #55H
```



```
MOV TAKEY, #AAH
MOV TAKEY, #5AH
```

1.4.4 Software Reset register (SWRES)

Mnemonic: SWRES								Address: E7H	
7	6	5	4	3	2	1	0	Reset	
SWRES [7:0]								00H	

SWRES [7:0]: Software reset register bit. These 8-bit is self-reset at the end of the reset procedure.
SWRES [7:0] = FFH, software reset.
SWRES [7:0] = 00H ~ FEH, MCU no action.

1.4.5 Reset Status Flag (RSTS)

Mnemonic: RSTS								Address: A1H	
7	6	5	4	3	2	1	0	Reset	
-	-	-	PDRF	WDTF	SWRF	LVRF	PORF	00H	

- PDRF: Pad reset flag.
When MCU is reset by reset pad, PDRF flag will be set to one by hardware. This flag clear by software.
- WDTF: Watchdog timer reset flag.
When MCU is reset by watchdog, WDTF flag will be set to one by hardware. This flag clear by software.
- SWRF: Software reset flag.
When MCU is reset by software, SWRF flag will be set to one by hardware. This flag clear by software.
- LVRF: Low voltage reset flag.
When MCU is reset by LVR, LVRF flag will be set to one by hardware. This flag clear by software.
- PORF: Power on reset flag.
When MCU is reset by POR, PORF flag will be set to one by hardware. This flag clear by software.

1.4.6 Example of software reset

```
MOV TAKEY, #55H
MOV TAKEY, #AAH
MOV TAKEY, #5AH ; enable SWRES write attribute
MOV SWRES, #FFH ; software reset MCU
```

1.5 Clocks

The default clock is the external crystal. This clock is used during the initialization stage. The major work of the initialization stage is to determine the clock source used in normal operation.

The internal clock sources are from the internal OSC with difference frequency division as given in table 1-1 , the clock source can set by writer or ICP .



Table 1-1: Selection of clock source

Clock source
external crystal
External OSC into Xtal1
22.1184 MHz from internal OSC
22.1184/2 MHz from internal OSC
22.1184/4 MHz from internal OSC
22.1184/8 MHz from internal OSC
22.1184/16 MHz from internal OSC

The internal OSC have $\pm 2\%$ variance at room temperature.



2 Instruction Set

All SM59R16G6 instructions are binary code compatible and perform the same functions as they do with the industry standard 8051. The following tables give a summary of the instruction set cycles of the SM59R16G6 Microcontroller core.

Table 2-1: Arithmetic operations

Mnemonic	Description	Code	Bytes	Cycles
ADD A,Rn	Add register to accumulator	28-2F	1	1
ADD A,direct	Add direct byte to accumulator	25	2	2
ADD A,@Ri	Add indirect RAM to accumulator	26-27	1	2
ADD A,#data	Add immediate data to accumulator	24	2	2
ADDC A,Rn	Add register to accumulator with carry flag	38-3F	1	1
ADDC A,direct	Add direct byte to A with carry flag	35	2	2
ADDC A,@Ri	Add indirect RAM to A with carry flag	36-37	1	2
ADDC A,#data	Add immediate data to A with carry flag	34	2	2
SUBB A,Rn	Subtract register from A with borrow	98-9F	1	1
SUBB A,direct	Subtract direct byte from A with borrow	95	2	2
SUBB A,@Ri	Subtract indirect RAM from A with borrow	96-97	1	2
SUBB A,#data	Subtract immediate data from A with borrow	94	2	2
INC A	Increment accumulator	04	1	1
INC Rn	Increment register	08-0F	1	2
INC direct	Increment direct byte	05	2	3
INC @Ri	Increment indirect RAM	06-07	1	3
INC DPTR	Increment data pointer	A3	1	1
DEC A	Decrement accumulator	14	1	1
DEC Rn	Decrement register	18-1F	1	2
DEC direct	Decrement direct byte	15	2	3
DEC @Ri	Decrement indirect RAM	16-17	1	3
MUL AB	Multiply A and B	A4	1	5
DIV	Divide A by B	84	1	5
DA A	Decimal adjust accumulator	D4	1	1



Table 2-2: Logic operations

Mnemonic	Description	Code	Bytes	Cycles
ANL A,Rn	AND register to accumulator	58-5F	1	1
ANL A,direct	AND direct byte to accumulator	55	2	2
ANL A,@Ri	AND indirect RAM to accumulator	56-57	1	2
ANL A,#data	AND immediate data to accumulator	54	2	2
ANL direct,A	AND accumulator to direct byte	52	2	3
ANL direct,#data	AND immediate data to direct byte	53	3	4
ORL A,Rn	OR register to accumulator	48-4F	1	1
ORL A,direct	OR direct byte to accumulator	45	2	2
ORL A,@Ri	OR indirect RAM to accumulator	46-47	1	2
ORL A,#data	OR immediate data to accumulator	44	2	2
ORL direct,A	OR accumulator to direct byte	42	2	3
ORL direct,#data	OR immediate data to direct byte	43	3	4
XRL A,Rn	Exclusive OR register to accumulator	68-6F	1	1
XRL A,direct	Exclusive OR direct byte to accumulator	65	2	2
XRL A,@Ri	Exclusive OR indirect RAM to accumulator	66-67	1	2
XRL A,#data	Exclusive OR immediate data to accumulator	64	2	2
XRL direct,A	Exclusive OR accumulator to direct byte	62	2	3
XRL direct,#data	Exclusive OR immediate data to direct byte	63	3	4
CLR A	Clear accumulator	E4	1	1
CPL A	Complement accumulator	F4	1	1
RL A	Rotate accumulator left	23	1	1
RLC A	Rotate accumulator left through carry	33	1	1
RR A	Rotate accumulator right	03	1	1
RRC A	Rotate accumulator right through carry	13	1	1
SWAP A	Swap nibbles within the accumulator	C4	1	1



Table 2-3: Data transfer

Mnemonic	Description	Code	Bytes	Cycles
MOV A,Rn	Move register to accumulator	E8-EF	1	1
MOV A,direct	Move direct byte to accumulator	E5	2	2
MOV A,@Ri	Move indirect RAM to accumulator	E6-E7	1	2
MOV A,#data	Move immediate data to accumulator	74	2	2
MOV Rn,A	Move accumulator to register	F8-FF	1	2
MOV Rn,direct	Move direct byte to register	A8-AF	2	4
MOV Rn,#data	Move immediate data to register	78-7F	2	2
MOV direct,A	Move accumulator to direct byte	F5	2	3
MOV direct,Rn	Move register to direct byte	88-8F	2	3
MOV direct1,direct2	Move direct byte to direct byte	85	3	4
MOV direct,@Ri	Move indirect RAM to direct byte	86-87	2	4
MOV direct,#data	Move immediate data to direct byte	75	3	3
MOV @Ri,A	Move accumulator to indirect RAM	F6-F7	1	3
MOV @Ri,direct	Move direct byte to indirect RAM	A6-A7	2	5
MOV @Ri,#data	Move immediate data to indirect RAM	76-77	2	3
MOV DPTR,#data16	Load data pointer with a 16-bit constant	90	3	3
MOVC A,@A+DPTR	Move code byte relative to DPTR to accumulator	93	1	3
MOVC A,@A+PC	Move code byte relative to PC to accumulator	83	1	3
MOVX A,@Ri	Move external RAM (8-bit addr.) to A	E2-E3	1	3
MOVX A,@DPTR	Move external RAM (16-bit addr.) to A	E0	1	3
MOVX @Ri,A	Move A to external RAM (8-bit addr.)	F2-F3	1	4
MOVX @DPTR,A	Move A to external RAM (16-bit addr.)	F0	1	4
PUSH direct	Push direct byte onto stack	C0	2	4
POP direct	Pop direct byte from stack	D0	2	3
XCH A,Rn	Exchange register with accumulator	C8-CF	1	2
XCH A,direct	Exchange direct byte with accumulator	C5	2	3
XCH A,@Ri	Exchange indirect RAM with accumulator	C6-C7	1	3
XCHD A,@Ri	Exchange low-order nibble indir. RAM with A	D6-D7	1	3



Table 2-4: Program branches

Mnemonic	Description	Code	Bytes	Cycles
ACALL addr11	Absolute subroutine call	xxx11	2	6
LCALL addr16	Long subroutine call	12	3	6
RET	from subroutine	22	1	4
RETI	from interrupt	32	1	4
AJMP addr11	Absolute jump	xxx01	2	3
LJMP addr16	Long iump	02	3	4
SJMP rel	Short jump (relative addr.)	80	2	3
JMP @A+DPTR	Jump indirect relative to the DPTR	73	1	2
JZ rel	Jump if accumulator is zero	60	2	3
JNZ rel	Jump if accumulator is not zero	70	2	3
JC rel	Jump if carry flag is set	40	2	3
JNC	Jump if carry flag is not set	50	2	3
JB bit,rel	Jump if direct bit is set	20	3	4
JNB bit,rel	Jump if direct bit is not set	30	3	4
JBC bit,direct rel	Jump if direct bit is set and clear bit	10	3	4
CJNE A,direct rel	Compare direct byte to A and jump if not equal	B5	3	4
CJNE A,#data rel	Compare immediate to A and jump if not equal	B4	3	4
CJNE Rn,#data rel	Compare immed. to reg. and jump if not equal	B8-BF	3	4
CJNE @Ri,#data rel	Compare immed. to ind. and jump if not equal	B6-B7	3	4
DJNZ Rn,rel	Decrement register and jump if not zero	D8-DF	2	3
DJNZ direct,rel	Decrement direct byte and jump if not zero	D5	3	4
NOP	No operation	00	1	1

Table 2-5: Boolean manipulation

Mnemonic	Description	Code	Bytes	Cycles
CLR C	Clear carry flag	C3	1	1
CLR bit	Clear direct bit	C2	2	3
SETB C	Set carry flag	D3	1	1
SETB bit	Set direct bit	D2	2	3
CPL C	Complement carry flag	B3	1	1
CPL bit	Complement direct bit	B2	2	3
ANL C,bit	AND direct bit to carry flag	82	2	2
ANL C,/bit	AND complement of direct bit to carry	B0	2	2
ORL C,bit	OR direct bit to carry flag	72	2	2
ORL C,/bit	OR complement of direct bit to carry	A0	2	2
MOV C,bit	Move direct bit to carry flag	A2	2	2
MOV bit,C	Move carry flag to direct bit	92	2	3



3 Memory Structure

The SM59R16G6 memory structure follows general 8052 structure. It integrate the expanded 1KB data memory and 64KB program memory.

3.1 Program Memory

The SM59R16G6 has 64KB on-chip flash memory which can be used as general program memory or EEPROM, on which include up to 4K byte specific ISP service program memory space. The address range for the 64K byte is \$0000 to \$FFFF. The address range for the ISP service program is \$F000 to \$FFFF. The ISP service program size can be partitioned as N blocks of 256 byte (N=0 to 16). When N=0 means no ISP service program space available, total 64K byte memory used as program memory. When N=1 means address \$FF00 to \$FFFF reserved for ISP service program. When N=2 means memory address \$FE00 to \$FFFF reserved for ISP service program...etc. Value N can be set and programmed into SM59R16G6 by the writer or ICP. It can be used to record any data as EEPROM. The procedure of this EEPROM application function is described in the section 16 on internal ISP.

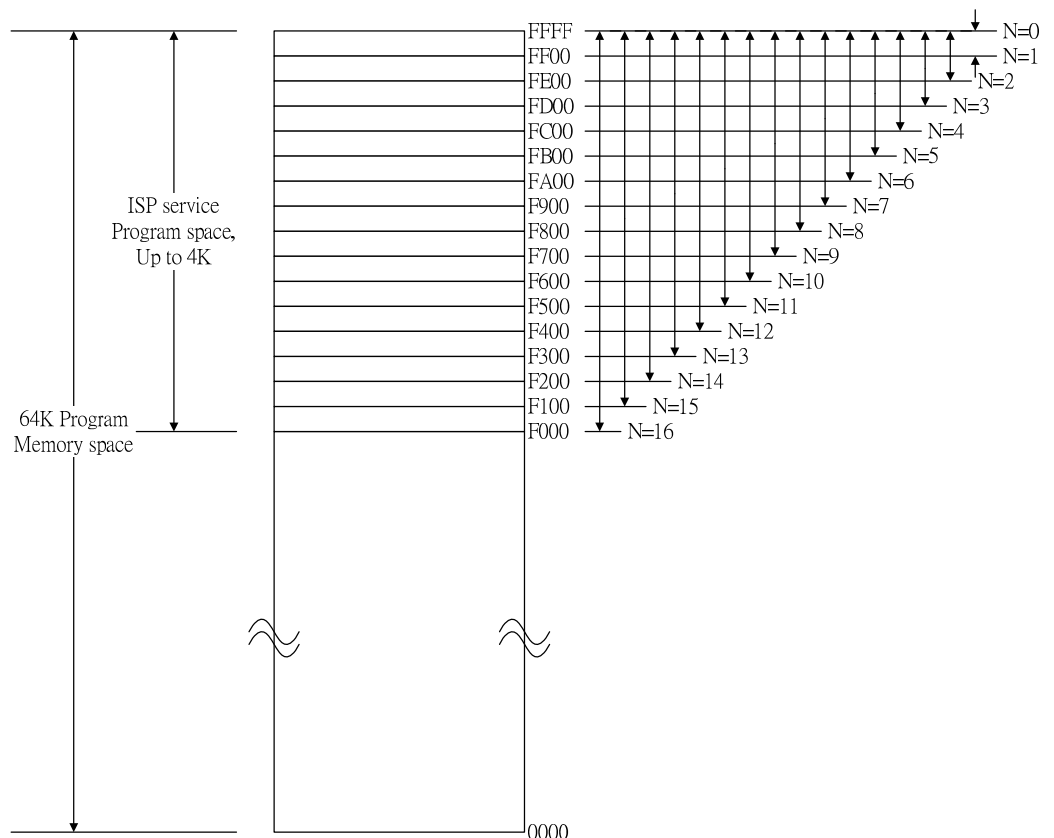

Fig. 3-1: SM59R16G6 programmable Flash

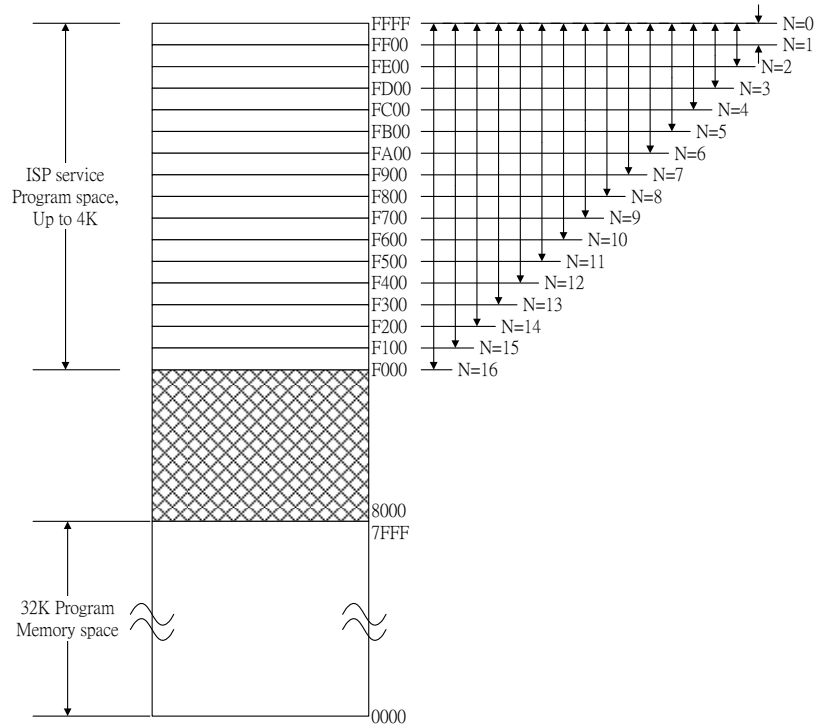

Fig. 3-2 : SM59R09G6 programmable Flash

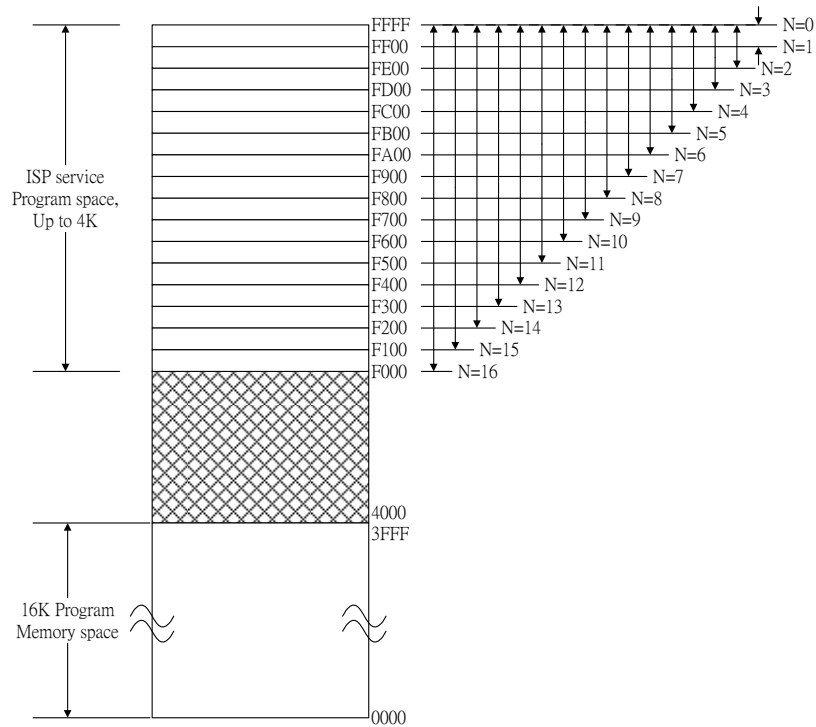

Fig. 3-3 : SM59R05G6 programmable Flash



3.2 Data Memory

The SM59R16G6 has 1K + 256Bytes on-chip SRAM, 256 Bytes of it are the same as general 8052 internal memory structure while the expanded 1KBytes on-chip SRAM can be accessed by external memory addressing method (by instruction MOVX.)

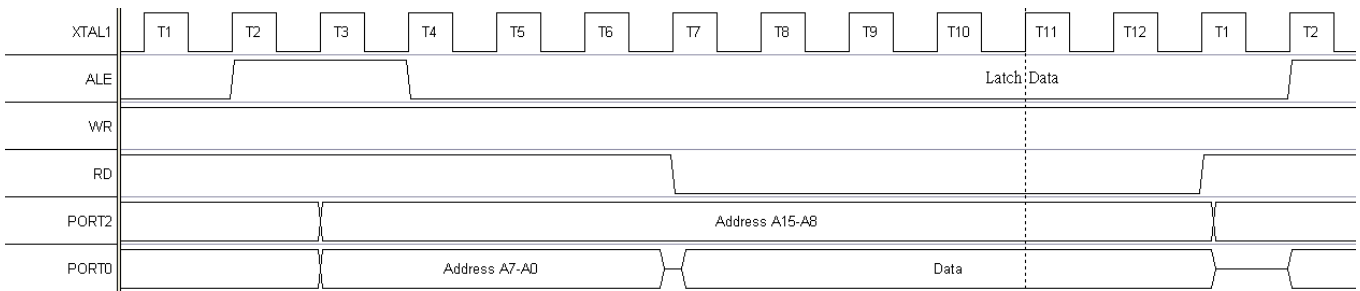

Fig 3-2 (a) : External memory access as read

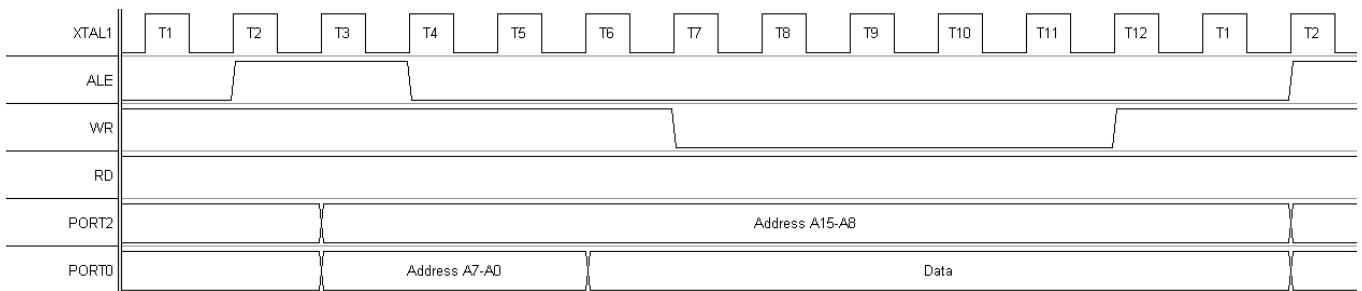

Fig 3-2 (b) : External memory access as write

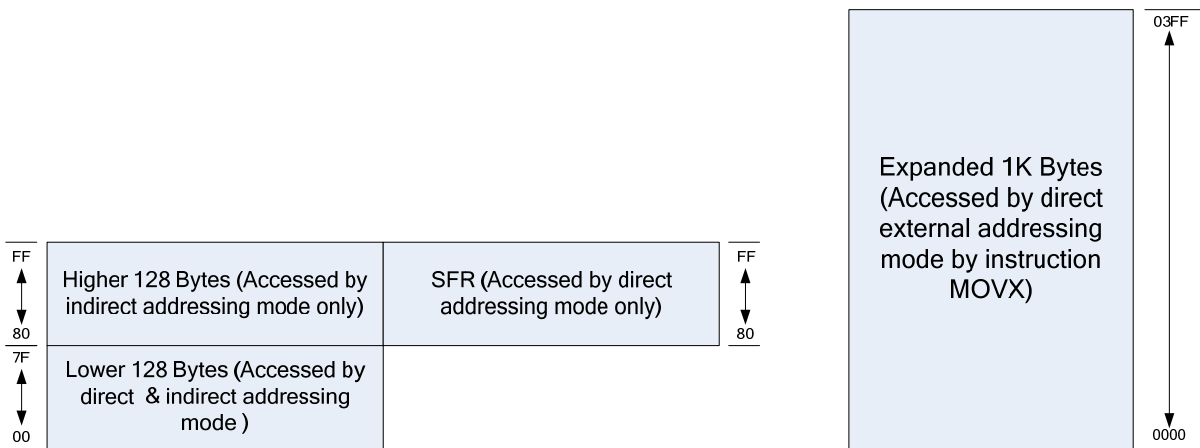

Fig. 3-3: RAM architecture

3.2.1 Data memory - lower 128 byte (00H to 7FH)

Data memory 00H to FFH is the same as 8052.

The address 00H to 7FH can be accessed by direct and indirect addressing



modes.

Address 00H to 1FH is register area.

Address 20H to 2FH is memory bit area.

Address 30H to 7FH is for general memory area.

3.2.2 Data memory - higher 128 byte (80H to FFH)

The address 80H to FFH can be accessed by indirect addressing mode.

Address 80H to FFH is data area.

3.2.3 Data memory - Expanded 1024 bytes (\$0000 to \$03FF)

From external address 0000H to 03FFH is the on-chip expanded SRAM area, total 1K Bytes. This area can be accessed by external direct addressing mode (by instruction MOVX).

If the address of instruction MOVX @DPTR is larger than 03FFH, the SM59R16G6 will generate the external memory control signal automatically.

The address space of instruction MOVX @Ri, i=0, 1 is determined by RCON [7:0] of special function register \$86 RCON (internal RAM control register). The default setting of RCON [7:0] is 00H (page0). One page of data RAM is 256 bytes.

When EMEN = 0, the internal 1K expanded RAM is enabled. If access memory space is more than 1K byte, the value of RCON is sent to Port2 to access external RAM.

When EMEN = 1, the internal 1K expanded RAM is disabled. The value of RCON is invalid and high byte address is decided by register context of Port2 register P2 [7:0].

MOVX @Ri, A MOVX A, @Ri	$0 \leq RCON[7:0] \leq 3$	$4 \leq RCON [7:0] \leq 255$
EMEN = 0	Addr [15:8] <= RCON[7:0]	Port2 [7:0] <= RCON[7:0]
EMEN = 1	Port2 [7:0] <= P2 [7:0]	Port2 [7:0] <= P2 [7:0]

4 CPU Engine

The SM59R16G6 engine is composed of four components:

- Control unit
- Arithmetic – logic unit
- Memory control unit
- RAM and SFR control unit

The SM59R16G6 engine allows to fetch instruction from program memory and to execute using RAM or SFR. The following paragraphs describe the main engine registers.

Mnemonic	Description	Direct	Bit 7	Bit 6	Bit 5	Bit 4	Bit 3	Bit 2	Bit 1	Bit 0	RESET
8051 Core											
ACC	Accumulator	E0H	ACC.7	ACC.6	ACC.5	ACC.4	ACC.3	ACC.2	ACC.1	ACC.0	00H
B	B register	F0H	B.7	B.6	B.5	B.4	B.3	B.2	B.1	B.0	00H
PSW	Program status word	D0H	CY	AC	F0	RS[1:0]		OV	PSW.1	P	00H
SP	Stack Pointer	81H	SP[7:0]								07H
DPL	Data pointer low 0	82H	DPL[7:0]								00H
DPH	Data pointer high 0	83H	DPH[7:0]								00H
DPL1	Data pointer low 1	84H	DPL1[7:0]								00H
DPH1	Data pointer high 1	85H	DPH1[7:0]								00H
AUX	Auxiliary register	91H	BRGS	-	P4SPI	P1UR	P4IIC	-	P2PWM	DPS	00H
RCON	Internal RAM control register	86H	RCON[7:0]								00H
IFCON	Interface control register	8FH	ITS	CDPR	-	-	ALEC[1:0]		EMEN	ISPE	00H

4.1 Accumulator

ACC is the Accumulator register. Most instructions use the accumulator to store the operand.

Mnemonic: ACC								Address: E0H	
7	6	5	4	3	2	1	0	Reset	
ACC.7	ACC.6	ACC.5	ACC.4	ACC.3	ACC.2	ACC.1	ACC.0	00H	

ACC[7:0]: The A (or ACC) register is the standard 8052 accumulator.

4.2 B Register

The B register is used during multiply and divide instructions. It can also be used as a scratch pad register to store temporary data.

Mnemonic: B								Address: F0H	
7	6	5	4	3	2	1	0	Reset	
B.7	B.6	B.5	B.4	B.3	B.2	B.1	B.0	00H	

B[7:0]: The B register is the standard 8052 register that serves as a second accumulator.



4.3 Program Status Word

Mnemonic: PSW							Address: D0H	
7	6	5	4	3	2	1	0	Reset
CY	AC	F0	RS [1:0]		OV	F1	P	00H

CY: Carry flag.

AC: Auxiliary Carry flag for BCD operations.

F0: General purpose Flag 0 available for user.

RS[1:0]: Register bank select, used to select working register bank.

RS[1:0]	Bank Selected	Location
00	Bank 0	00H – 07H
01	Bank 1	08H – 0FH
10	Bank 2	10H – 17H
11	Bank 3	18H – 1FH

OV: Overflow flag.

F1: General purpose Flag 1 available for user.

P: Parity flag, affected by hardware to indicate odd/even number of “one” bits in the Accumulator, i.e. even parity.

4.4 Stack Pointer

The stack pointer is a 1-byte register initialized to 07H after reset. This register is incremented before PUSH and CALL instructions, causing the stack to start from location 08H.

Mnemonic: SP							Address: 81H	
7	6	5	4	3	2	1	0	Reset
SP [7:0]								07H

SP[7:0]: The Stack Pointer stores the scratchpad RAM address where the stack begins. In other words, it always points to the top of the stack.

4.5 Data Pointer

The data pointer (DPTR) is 2-bytes wide. The lower part is DPL, and the highest is DPH. It can be loaded as a 2-byte register (e.g. MOV DPTR, #data16) or as two separate registers (e.g. MOV DPL, #data8). It is generally used to access the external code or data space (e.g. MOVC A, @A+DPTR or MOVX A, @DPTR respectively).

Mnemonic: DPL							Address: 82H	
7	6	5	4	3	2	1	0	Reset
DPL [7:0]								00H

DPL[7:0]: Data pointer Low 0

Mnemonic: DPH							Address: 83H	
7	6	5	4	3	2	1	0	Reset
DPH [7:0]								00H

DPH [7:0]: Data pointer High 0



4.6 Data Pointer 1

The Dual Data Pointer accelerates the moves of data block. The standard DPTR is a 16-bit register that is used to address external memory or peripherals. In the SM59R16G6 core the standard data pointer is called DPTR, the second data pointer is called DPTR1. The data pointer select bit chooses the active pointer. The data pointer select bit is located in LSB of AUX register (DPS).

The user switches between pointers by toggling the LSB of AUX register. All DPTR-related instructions use the currently selected DPTR for any activity.

Mnemonic: DPL1							Address: 84H	
7	6	5	4	3	2	1	0	Reset
DPL1 [7:0]								00H

DPL1[7:0]: Data pointer Low 1

Mnemonic: DPH1							Address: 85H	
7	6	5	4	3	2	1	0	Reset
DPH1 [7:0]								00H

DPH1[7:0]: Data pointer High 1

Mnemonic: AUX								Address: 91H	
7	6	5	4	3	2	1	0	Reset	
BRGS	-	P4SPI	P1UR	P4IIC	-	P2PWM	DPS	00H	

DPS: Data Pointer selects register.
DPS = 1 is selected DPTR1.

4.7 Internal RAM control register

SM59R16G6 has 1K byte on-chip expanded RAM which can be accessed by external memory addressing method only (By instruction MOVX). The address space of instruction MOVX @Ri, i = 0, 1 is determined by RCON [7:0] of RCON. The default setting of RCON [7:0] is 00H (page0).

Mnemonic: RCON							Address: 86H	
7	6	5	4	3	2	1	0	Reset
RCON[7:0]								00H

4.8 Interface control register

Mnemonic: IFCON						Address: 8FH		
7	6	5	4	3	2	1	0	Reset
ITS	CDPR	-	-	ALEC[1:0]	EMEN	ISPE	00H	

ITS: Instruction timing select. (default is 2T)
ITS = 0, 2T instruction mode.
ITS = 1, 1T instruction mode.
CDPR: code protect (Read Only)
ALEC[1:0]: ALE output control register.

Specifications subject to change without notice contact your sales representatives for the most recent information.



ALEC[1:0]	ALE Output
00	Always output
01	No ALE output
10	Only Read or Write have ALE output
11	reserved

EMEN: Internal 1K SRAM disable.(default is enable)

EMEN = 0, Enable internal 1K RAM.

EMEN = 1, Disable internal 1K RAM.

ISPE: ISP function enable bit

ISPE = 1, enable ISP function

ISPE = 0, disable ISP function

5 GPIO

The SM59R16G6 has six I/O ports: Port 0, Port 1, Port 2, Port 3, Port 4, and Port 5. Ports 0, 1, 2, 3 are 8-bit ports, Port 4 is a 7-bit port and Port 5 is a 6-bit port. These are: quasi-bidirectional (standard 8051 port outputs), push-pull, open drain, and input-only. Two configuration registers for each port select the output type for each port pin. All I/O port pins on the SM59R16G6 may be configured by software to one of four types on a pin-by-pin basis, shown as below:

Mnemonic	Description	Direct	Bit 7	Bit 6	Bit 5	Bit 4	Bit 3	Bit 2	Bit 1	Bit 0	RESET
I/O port function register											
P0M0	Port 0 output mode 0	D2H					P0M0 [7:0]				00H
P0M1	Port 0 output mode 1	D3H					P0M1 [7:0]				00H
P1M0	Port 1 output mode 0	D4H					P1M0 [7:0]				00H
P1M1	Port 1 output mode 1	D5H					P1M1 [7:0]				00H
P2M0	Port 2 output mode 0	D6H					P2M0 [7:0]				00H
P2M1	Port 2 output mode 1	D7H					P2M1 [7:0]				00H
P3M0	Port 3 output mode 0	DAH					P3M0 [7:0]				00H
P3M1	Port 3 output mode 1	DBH					P3M1 [7:0]				00H
P4M0	Port 4 output mode 0	DCH	-				P4M0 [6:0]				00H
P4M1	Port 4 output mode 1	DDH	-				P4M1 [6:0]				00H
P5M0	Port 5 output mode 0	DEH	-						P5M0 [5:0]		00H
P5M1	Port 5 output mode 1	DFH	-						P5M1 [5:0]		00H

PxM1.y	PxM0.y	Port output mode
0	0	Quasi-bidirectional (standard 8051 port outputs) (pull-up)
0	1	Push-pull
1	0	Input only (high-impedance)
1	1	Open drain

The OCI_SCL, ALE and OCI_SDA can be define as P4.4, P4.5 and P4.6 by writer or ISP.

The XTAL2 and XTAL1 can define as P5.4 and P5.5 by writer or ISP, when user use internal OSC as system clock; when user use external OSC as system clock and input into XTAL1, Only XTAL2 can be defined as P5.4.

For general-purpose applications, every pin can be assigned to either high or low independently as given below:

Mnemonic	Description	Direct	Bit 7	Bit 6	Bit 5	Bit 4	Bit 3	Bit 2	Bit 1	Bit 0	RESET
Ports											
Port 5	Port 5	D8H	-	-	P5.5	P5.4	P5.3	P5.2	P5.1	P5.0	0FH
Port 4	Port 4	E8H	-	P4.6	P4.5	P4.4	P4.3	P4.2	P4.1	P4.0	FFH
Port 3	Port 3	B0H	P3.7	P3.6	P3.5	P3.4	P3.3	P3.2	P3.1	P3.0	FFH
Port 2	Port 2	A0H	P2.7	P2.6	P2.5	P2.4	P2.3	P2.2	P2.1	P2.0	FFH
Port 1	Port 1	90H	P1.7	P1.6	P1.5	P1.4	P1.3	P1.2	P1.1	P1.0	FFH
Port 0	Port 0	80H	P0.7	P0.6	P0.5	P0.4	P0.3	P0.2	P0.1	P0.0	FFH



Mnemonic: P0								Address: 80h	
7	6	5	4	3	2	1	0	Reset	
P0.7	P0.6	P0.5	P0.4	P0.3	P0.2	P0.1	P0.0	FFH	

P0.7~ 0: Port0 [7] ~ Port0 [0]

Mnemonic: P1								Address: 90H	
7	6	5	4	3	2	1	0	Reset	
P1.7	P1.6	P1.5	P1.4	P1.3	P1.2	P1.1	P1.0	FFH	

P1.7~ 0: Port1 [7] ~ Port1 [0]

Mnemonic: P2								Address: A0H	
7	6	5	4	3	2	1	0	Reset	
P2.7	P2.6	P2.5	P2.4	P2.3	P2.2	P2.1	P2.0	FFH	

P2.7~ 0: Port2 [7] ~ Port2 [0]

Mnemonic: P3								Address: B0H	
7	6	5	4	3	2	1	0	Reset	
P3.7	P3.6	P3.5	P3.4	P3.3	P3.2	P3.1	P3.0	FFH	

P3.7~ 0: Port3 [7] ~ Port3 [0]

Mnemonic: P4								Address: E8H	
7	6	5	4	3	2	1	0	Reset	
-	P4.6	P4.5	P4.4	P4.3	P4.2	P4.1	P4.0	FFH	

P4.6~ 0: Port4 [6] ~ Port4 [0]

Mnemonic: P5								Address: D8H	
7	6	5	4	3	2	1	0	Reset	
-	-	P5.5	P5.4	P5.3	P5.2	P5.1	P5.0	3FH	

P5.5~ 0: Port5 [5] ~ Port5 [0]

6 Timer 0 and Timer 1

The SM59R16G6 has three 16-bit timer/counter registers: Timer 0, Timer 1 and Timer 2. All can be configured for counter or timer operations.

In timer mode, the Timer 0 register or Timer 1 register is incremented every 1/12/96 machine cycles, which means that it counts up after every 1/12/96 periods of the clock signal. It's dependent on SFR(PFCON).

In counter mode, the register is incremented when the falling edge is observed at the corresponding input pin T0 or T1. Since it takes 2 machine cycles to recognize a 1-to-0 event, the maximum input count rate is 1/2 of the oscillator frequency. There are no restrictions on the duty cycle, however to ensure proper recognition of 0 or 1 state, an input should be stable for at least 1 machine cycle.

Four operating modes can be selected for Timer 0 and Timer 1. Two Special Function registers (TMOD and TCON) are used to select the appropriate mode.

Mnemonic	Description	Direct	Bit 7	Bit 6	Bit 5	Bit 4	Bit 3	Bit 2	Bit 1	Bit 0	RESET
Timer 0 and 1											
TL0	Timer 0 , low byte	8AH	TL0[7:0]								00H
TH0	Timer 0 , high byte	8CH	TH0[7:0]								00H
TL1	Timer 1 , low byte	8BH	TL1[7:0]								00H
TH1	Timer 1 , high byte	8DH	TH1[7:0]								00H
TMOD	Timer Mode Control	89H	GATE	C/T	M1	M0	GATE	C/T	M1	M0	00H
TCON	Timer/Counter Control	88H	TF1	TR1	TF0	TR0	IE1	IT1	IE0	IT0	00H
PFCON	Peripheral Frequency control register	D9H			S0RELPS[1:0]		T1PS[1:0]		T0PS[1:0]		00H

6.1 Timer/counter mode control register (TMOD)

Mnemonic: TMOD								Address: 89H	
7	6	5	4	3	2	1	0	Reset	
GATE	C/T	M1	M0	GATE	C/T	M1	M0	00H	
Timer 1				Timer 0					

GATE: If set, enables external gate control (pin INT0 or INT1 for Counter 0 or 1, respectively). When INT0 or INT1 is high, and TRx bit is set (see TCON register), a counter is incremented every falling edge on T0 or T1 input pin

C/T: Selects Timer or Counter operation. When set to 1, a counter operation is performed, when cleared to 0, the corresponding register will function as a timer.

M[1:0]: Selects mode for Timer/Counter 0 or Timer/Counter 1.

M1	M0	Mode	Function
0	0	Mode0	13-bit counter/timer, with 5 lower bits in TL0 or TL1 register and 8 bits in TH0 or TH1 register (for Timer 0 and Timer 1, respectively). The 3

Specifications subject to change without notice contact your sales representatives for the most recent information.



			high order bits of TL0 and TL1 are hold at zero.
0	1	Mode1	16-bit counter/timer.
1	0	Mode2	8-bit auto-reload counter/timer. The reload value is kept in TH0 or TH1, while TL0 or TL1 is incremented every machine cycle. When TLx overflows, a value from THx is copied to TLx.
1	1	Mode3	If Timer 1 M1 and M0 bits are set to 1, Timer 1 stops. If Timer 0 M1 and M0 bits are set to 1, Timer 0 acts as two independent 8 bit timers / counters.

6.2 Timer/counter control register (TCON)

Mnemonic: TCON								Address: 88H
7	6	5	4	3	2	1	0	Reset
TF1	TR1	TF0	TR0	IE1	IT1	IE0	IT0	00H

- TF1: Timer 1 overflow flag set by hardware when Timer 1 overflows. This flag can be cleared by software and is automatically cleared when interrupt is processed.
- TR1: Timer 1 Run control bit. If cleared, Timer 1 stops.
- TF0: Timer 0 overflow flag set by hardware when Timer 0 overflows. This flag can be cleared by software and is automatically cleared when interrupt is processed.
- TR0: Timer 0 Run control bit. If cleared, Timer 0 stops.
- IE1: Interrupt 1 edge flag. Set by hardware, when falling edge on external pin INT1 is observed. Cleared when interrupt is processed.
- IT1: Interrupt 1 type control bit. Selects falling edge or low level on input pin to cause interrupt.
- IE0: Interrupt 0 edge flag. Set by hardware, when falling edge on external pin INTO is observed. Cleared when interrupt is processed.
- IT0: Interrupt 0 type control bit. Selects falling edge or low level on input pin to cause interrupt.

6.3 Peripheral Frequency control register (PFCN)

Mnemonic: PFCN						Address: D9H		
7	6	5	4	3	2	1	0	Reset
-	-	S0RELPS[1:0]	T1PS[1:0]			T0PS[1:0]		00H

T0PS[1:0]: Timer0 Prescaler select

T0PS[1:0]	Prescaler
00	Fosc/12
01	Fosc
10	Fosc/96
11	reserved

T1PS[1:0]: Timer1 Prescaler select

T1PS[1:0]	Prescaler
00	Fosc/12
01	Fosc
10	Fosc/96
11	reserved



6.4 Mode 0 (13-bit Counter/Timer)

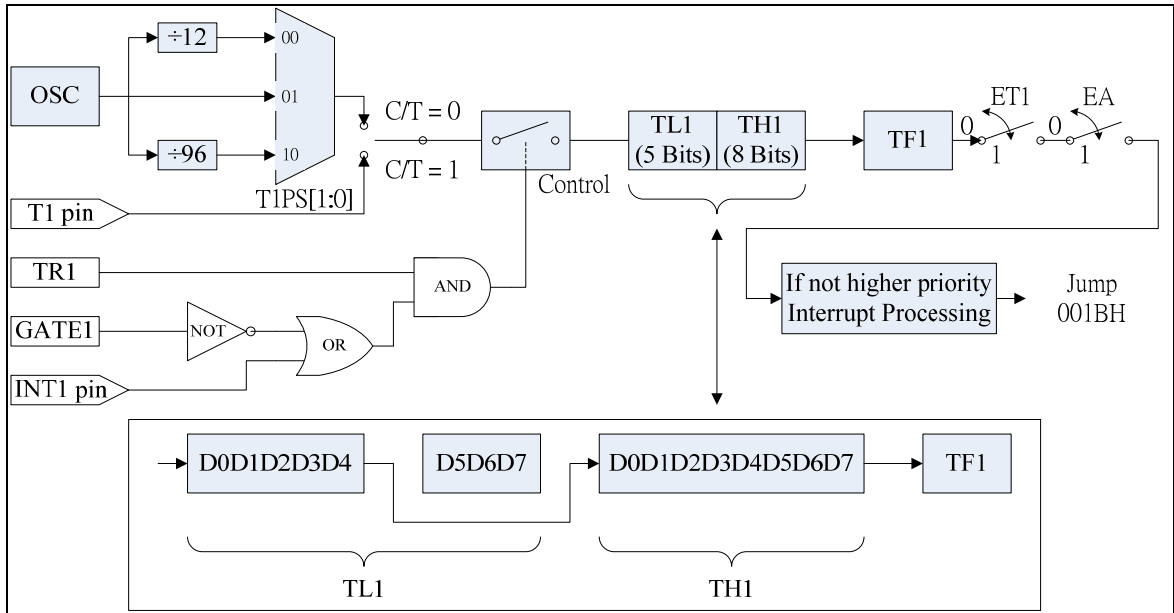

6.5 Mode 1 (16-bit Counter/Timer)

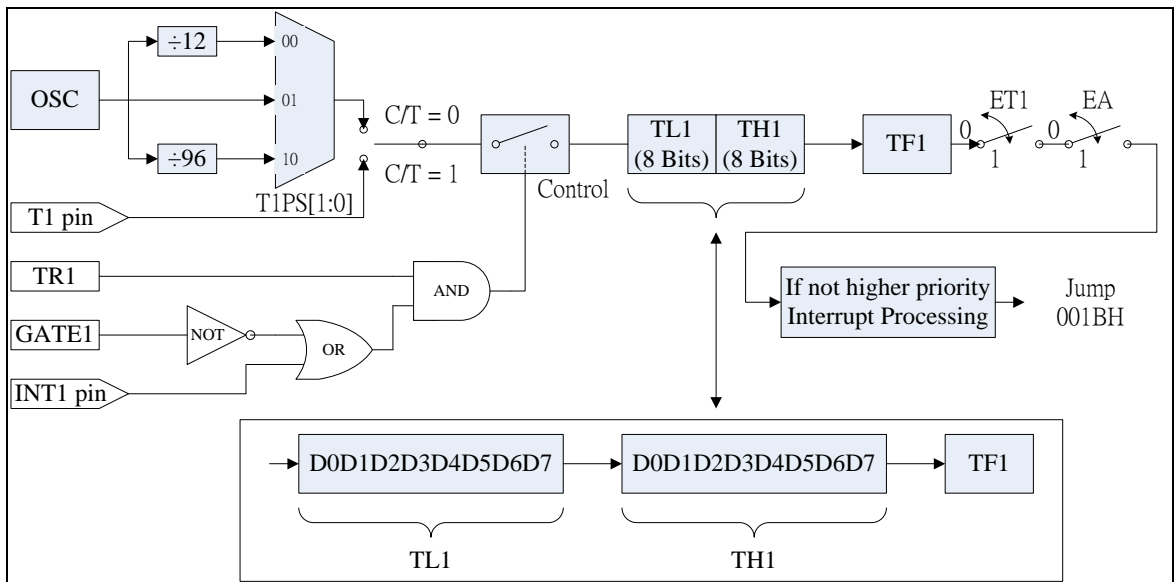



6.6 Mode 2 (8-bit auto-reload Counter/Timer)

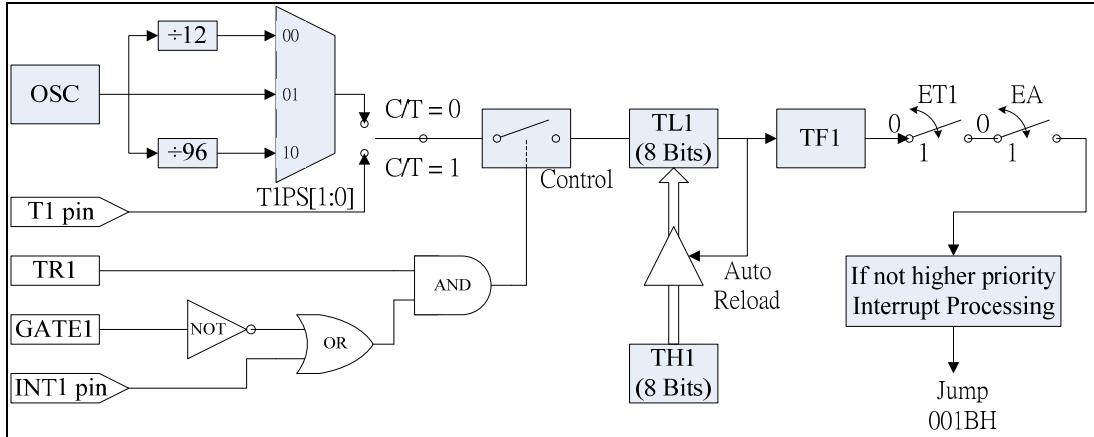

6.7 Mode 3 (Timer 0 acts as two independent 8 bit Timers / Counters)

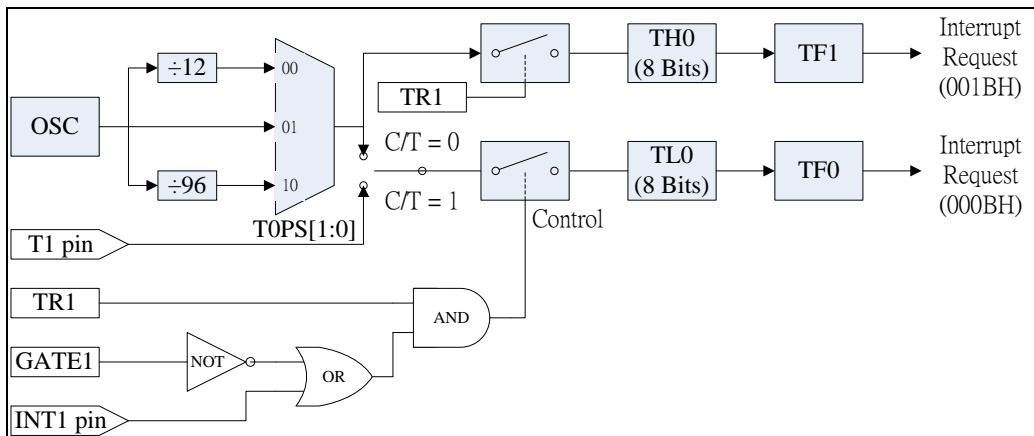



7 Timer 2 and Capture/Compare Unit

Timer 2 is not only a 16-bit timer, also a 4-channel unit with compare, capture and reload functions. It is very similar to the programmable counter array (PCA) in some other MCUs except pulse width modulation (PWM).

Mnemonic	Description	Direct	Bit 7	Bit 6	Bit 5	Bit 4	Bit 3	Bit 2	Bit 1	Bit 0	RESET
Timer 2 and Capture Compare Unit											
AUX2	Auxiliary register2	92H	-	-	-	-	-	-	P42CC[1:0]		
T2CON	Timer 2 control	C8H	T2PS[2:0]			T2R[1:0]		-	T2I[1:0]		00H
CCCON	Compare/Capture Control	C9H	CC13	CC12	CC11	CC10	CCF3	CCF2	CCF1	CCF0	00H
CCEN	Compare/Capture Enable register	C1H	-	COCAM1[2:0]			-	COCAM0[2:0]			00H
CCEN2	Compare/Capture Enable 2 register	D1H	-	COCAM3[2:0]			-	COCAM2[2:0]			00H
TL2	Timer 2, low byte	CCH	TL2[7:0]								00H
TH2	Timer 2, high byte	CDH	TH2[7:0]								00H
CRCL	Compare/Reload/Capture register, low byte	CAH	CRCL[7:0]								00H
CRCH	Compare/Reload/Capture register, high byte	CBH	CRCH[7:0]								00H
CCL1	Compare/Capture register 1, low byte	C2H	CCL1[7:0]								00H
CCH1	Compare/Capture register 1, high byte	C3H	CCH1[7:0]								00H
CCL2	Compare/Capture register 2, low byte	C4H	CCL2[7:0]								00H
CCH2	Compare/Capture register 2, high byte	C5H	CCH2[7:0]								00H
CCL3	Compare/Capture register 3, low byte	C6H	CCL3[7:0]								00H
CCH3	Compare/Capture register 3, high byte	C7H	CCH3[7:0]								00H

Mnemonic: AUX2

Address: 92H

7	6	5	4	3	2	1	0	Reset
-	-	-	-	-	-	P42CC[1:0]		00H

- P42CC[1:0] 00: Capture/Compare function on Port1.
01: Capture/Compare function on Port2
10: Capture/Compare function on Port4
11: reserved



Mnemonic: T2CON				Address: C8H				
7	6	5	4	3	2	1	0	Reset
T2PS[2:0]			T2R[1:0]		-	T2I[1:0]		00H

T2PS[2:0]: Prescaler select bit:

- T2PS = 000 – timer 2 is clocked with the oscillator frequency.
- T2PS = 001 – timer 2 is clocked with 1/2 of the oscillator frequency.
- T2PS = 010 – timer 2 is clocked with 1/4 of the oscillator frequency.
- T2PS = 011 – timer 2 is clocked with 1/6 of the oscillator frequency.
- T2PS = 100 – timer 2 is clocked with 1/8 of the oscillator frequency.
- T2PS = 101 – timer 2 is clocked with 1/12 of the oscillator frequency.
- T2PS = 110 – timer 2 is clocked with 1/24 of the oscillator frequency.

T2R[1:0]: Timer 2 reload mode selection

- T2R[1:0] = 0X – Reload disabled
- T2R[1:0] = 10 – Mode 0
- T2R[1:0] = 11 – Mode 1

T2I[1:0]: Timer 2 input selection

- T2I[1:0] = 00 – Timer 2 stop
- T2I[1:0] = 01 – Input frequency f/12 or f/24
- T2I[1:0] = 10 – Timer 2 is incremented by external signal at pin T2
- T2I[1:0] = 11 – internal clock input is gated to the Timer 2

Mnemonic: CCON				Address: C9H				
7	6	5	4	3	2	1	0	Reset
CCI3	CCI2	CCI1	CCI0	CCF3	CCF2	CCF1	CCF0	00H

CCI3: Compare/Capture 3 interrupt control bit.

“1” is enable.

CCI2: Compare/Capture 2 interrupt control bit.

“1” is enable.

CCI1: Compare/Capture 1 interrupt control bit.

“1” is enable.

CCI0: Compare/Capture 0 interrupt control bit.

“1” is enable.

CCF3: Compare/Capture 3 flag set by hardware. This flag can be cleared by software.

CCF2: Compare/Capture 2 flag set by hardware. This flag can be cleared by software.

CCF1: Compare/Capture 1 flag set by hardware. This flag can be cleared by software.

CCF0: Compare/Capture 0 flag set by hardware. This flag can be cleared by software.

Compare/Capture interrupt share T2 interrupt vector.

Mnemonic: CCEN				Address: C1H				
7	6	5	4	3	2	1	0	Reset
-	COCAM1[2:0]			-	COCAM0[2:0]		00H	

COCAM1[2:0] 000: Compare/Capture disable

001: Compare enable but no output on Pin

010: Compare mode 0

011: Compare mode 1

100: Capture on rising edge at pin CC1

101: Capture on falling edge at pin CC1

110: Capture on both rising and falling edge at pin CC1



111: Capture on write operation into register CC1
COCAM0[2:0] 000: Compare/Capture disable
001: Compare enable but no output on Pin
010: Compare mode 0
011: Compare mode 1
100: Capture on rising edge at pin CC0
101: Capture on falling edge at pin CC0
110: Capture on both rising and falling edge at pin CC0
111: Capture on write operation into register CC0

Mnemonic: CCEN2				Address: D1H				
7	6	5	4	3	2	1	0	Reset
--	COCAM3[2:0]			--	COCAM2[2:0]		0	00H

COCAM3[2:0] 000: Compare/Capture disable
001: Compare enable but no output on Pin
010: Compare mode 0
011: Compare mode 1
100: Capture on rising edge at pin CC3
101: Capture on falling edge at pin CC3
110: Capture on both rising and falling edge at pin CC3
111: Capture on write operation into register CC3
COCAM2[2:0] 000: Compare/Capture disable
001: Compare enable but no output on Pin
010: Compare mode 0
011: Compare mode 1
100: Capture on rising edge at pin CC2
101: Capture on falling edge at pin CC2
110: Capture on both rising and falling edge at pin CC2
111: Capture on write operation into register CC2

7.1 Timer 2 function

Timer 2 can operate as timer, event counter, or gated timer as explained later.

7.1.1 Timer mode

In this mode Timer 2 can be incremented in various frequency that depending on the prescaler. The prescaler is selected by bit T2PS[2:0] in register T2CON.

7.1.2 Event counter mode

In this mode, the timer is incremented when external signal T2 change value from 1 to 0. The T2 input is sampled in every cycle. Timer 2 is incremented in the cycle following the one in which the transition was detected.



7.1.3 Gated timer mode

In this mode, the internal clock which incremented timer 2 is gated by external signal T2.

7.1.4 Reload of Timer 2

Reload (16-bit reload from the crc register) can be executed in the following two modes:

Mode 0: Reload signal is generate by a Timer 2 overflows - auto reload

Mode 1: Reload signal is generate by a negative transition at the corresponding input pin T2EX.

7.2 Compare function

In the four independent comparators, the value stored in any compare/capture register is compared with the contents of the timer register. The compare modes 0 and 1 are selected by bit C0CAMx. In both compare modes, the results of comparison arrives at Port 1 within the same machine cycle in which the internal compare signal is activated.

7.2.1 Compare Mode 0

In mode 0, when the value in Timer 2 equals the value of the compare register, the output signal changes from low to high. It goes back to a low level on timer overflow. In this mode, writing to the port will have no effect, because the input line from the internal bus and the write-to-latch line are disconnected. The following figure illustrates the function of compare mode 0.

Fig. 7-1: Compare mode 0 function

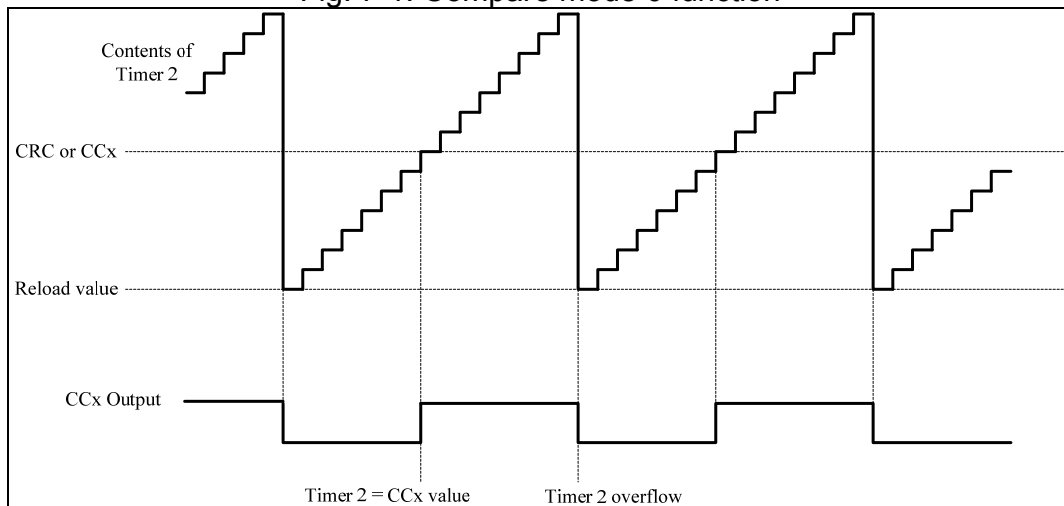

7.2.2 Compare Mode 1

In compare mode 1, the transition of the output signal can be determined by software. A timer 2 overflow causes no output change. In this mode, both transitions of a signal can be controlled. Fig. 7-2 shows a functional diagram of a register/port configuration in compare Mode 1. In compare Mode 1, the value is written first to the "Shadow Register", when compare signal is active, this value is



transferred to the output register.

Fig. 7-2: Compare mode 1 function

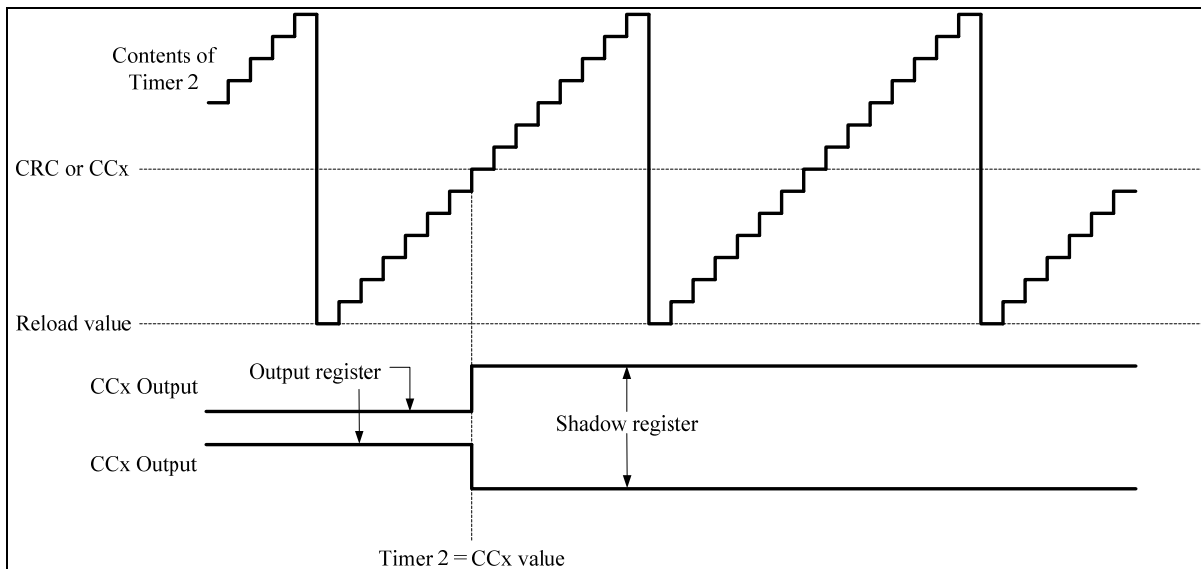
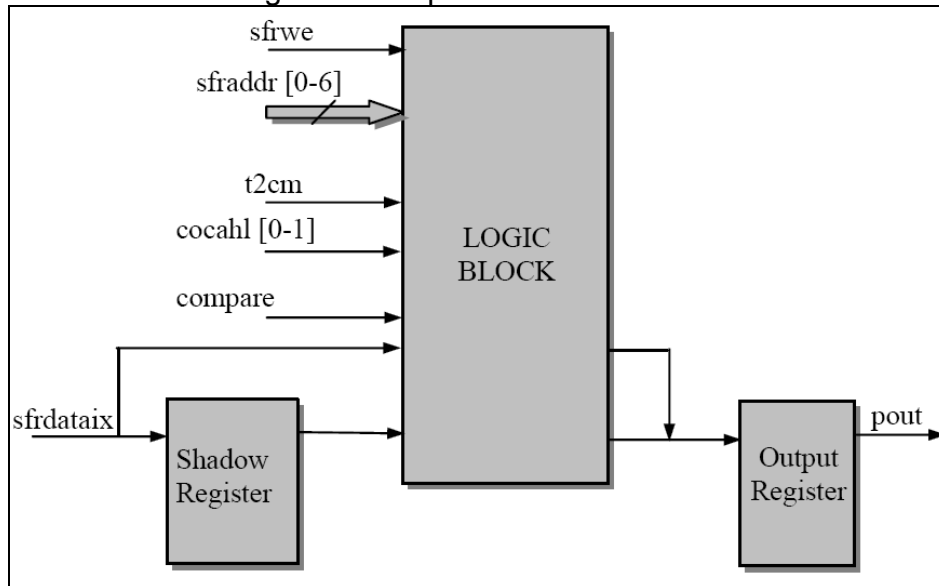

7.3 Capture function

Actual timer/counter contents can be saved into registers CCx or CRC upon an external event (mode 0) or a software write operation (mode 1).



7.3.1 Capture Mode 0

In mode 0, value capture of Timer 2 is executed when:

- (a) Rising edge on input CC0-CC3
- (b) Falling edge on input CC0-CC3
- (c) Both rising and falling edge on input CC0-CC3

The contents of Timer 2 will be latched into the appropriate capture register.

7.3.2 Capture Mode 1

In mode 1, value capture of timer 2 is caused by writing any value into the low-order byte of the dedicated capture register. The value written to the capture register is irrelevant to this function. The contents of Timer 2 will be latched into the appropriate capture register.



8 Serial interface 0

There are one serial interfaces for data communication in SM59R16G6, they are the so called UART0.

As the conventional UART, the communication speed can be selected by configuring the baud rate in SFRs.

These two serial buffers consists of two separate registers, a transmit buffer and a receive buffer. Writing data to the SFR S0BUF sets this data in serial output buffer and starts the transmission. Reading from the S0BUF reads data from the serial receive buffer. The serial port can simultaneously transmit and receive data. It can also buffer 1 byte at receive, which prevents the receive data from being lost if the CPU reads the second byte before the transmission of the first byte is completed.

Mnemonic	Description	Direct	Bit 7	Bit 6	Bit 5	Bit 4	Bit 3	Bit 2	Bit 1	Bit 0	RESET
Serial interface 0 and 1											
PCON	Power control	87H	SMOD	-	-	-	-	-	STOP	IDLE	40H
AUX	Auxiliary register	91H	BRGS	-	P4SPI	P1UR	P4IIC	-	P2PWM	DPS	00H
S0CON	Serial Port 0 control register	98H	SM0	SM1	SM20	REN0	TB80	RB80	TIO	RI0	00H
S0RELL	Serial Port 0 reload register low byte	AAH	S0REL .7	S0REL .6	S0REL .5	S0REL .4	S0REL .3	S0REL .2	S0REL .1	S0REL .0	00H
S0RELH	Serial Port 0 reload register high byte	BAH	-	-	-	-	-	-	S0REL .9	S0REL .8	00H
S0BUF	Serial Port 0 data buffer	99H	S0BUF[7:0]								00H
PFCON	Peripheral Frequency control register	D9H	-	-	S0RELPS[1:0]		T1PS[1:0]		TOPS[1:0]		00H

Mnemonic: AUX

Address: 91H

7	6	5	4	3	2	1	0	Reset
BRGS	-	P4SPI	P1UR	P4IIC	-	P2PWM	DPS	00H

P1UR: P1UR = 0 – Serial interface 0 function on P3.

P1UR = 1 – Serial interface 0 function on P1.

Mnemonic: S0CON

Address: 98H

7	6	5	4	3	2	1	0	Reset
SM0	SM1	SM20	REN0	TB80	RB80	TIO	RI0	00H



SM0,SM1: Serial Port 0 mode selection.

SM0	SM1	Mode
0	0	0
0	1	1
1	0	2
1	1	3

The 4 modes in UART0, Mode 0 ~ 3, are explained later.

SM20: Enables multiprocessor communication feature

REN0: If set, enables serial reception. Cleared by software to disable reception.

TB80: The 9th transmitted data bit in modes 2 and 3. Set or cleared by the CPU depending on the function it performs such as parity check, multiprocessor communication etc.

RB80: In modes 2 and 3, it is the 9th data bit received. In mode 1, if SM20 is 0, RB80 is the stop bit. In mode 0, this bit is not used. Must be cleared by software.

T10: Transmit interrupt flag, set by hardware after completion of a serial transfer. Must be cleared by software.

RI0: Receive interrupt flag, set by hardware after completion of a serial reception. Must be cleared by software.

Mnemonic: PFCON

Address: D9H

7	6	5	4	3	2	1	0	Reset
-	-	S0RELPS[1:0]		T1PS[1:0]		T0PS[1:0]		00H

S0RELPS[1:0]: S0REL Prescaler select

S0RELPS[1:0]	Prescaler
00	Fosc/64
01	Fosc/32
10	Fosc/16
11	Fosc/8

T1PS[1:0]: Timer1 Prescaler select

T1PS[1:0]	Prescaler
00	Fosc/12
01	Fosc
10	Fosc/96
11	reserved



8.1 Serial interface 0

The Serial Interface 0 can operate in the following 4 modes:

SM0	SM1	Mode	Description	Board Rate
0	0	0	Shift register	Fosc/12
0	1	1	8-bit UART	Variable
1	0	2	9-bit UART	Fosc/32 or Fosc/64
1	1	3	9-bit UART	Variable

Here Fosc is the crystal or oscillator frequency.

8.1.1 Mode 0

Pin RXD0 serves as input and output. TXD0 outputs the shift clock. 8 bits are transmitted with LSB first. The baud rate is fixed at 1/12 of the crystal frequency. Reception is initialized in Mode 0 by setting the flags in S0CON as follows: RI0 = 0 and REN0 = 1. In the other modes, a start bit when REN0 = 1 starts receiving serial data.



Fig. 8-1: Transmit mode 0 for Serial 0

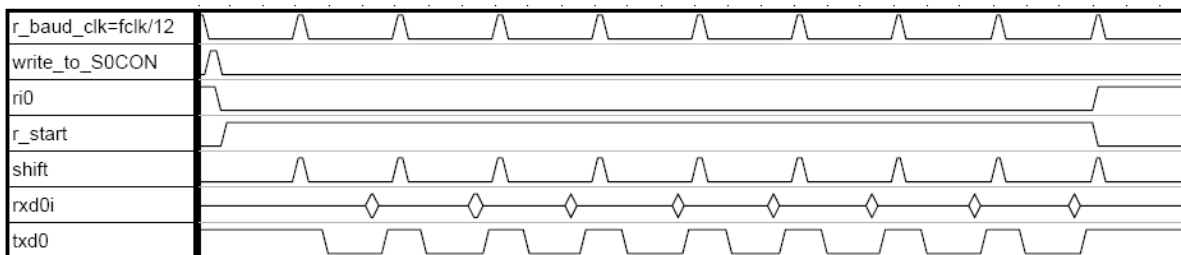

Fig. 8-2: Receive mode 0 for Serial 0

8.1.2 Mode 1

Here Pin RXD0 serves as input, and TXD0 serves as serial output. No external shift clock is used, 10 bits are transmitted: a start bit (always 0), 8 data bits (LSB first), and a stop bit (always 1). On receive, a start bit synchronizes the transmission, 8 data bits are available by reading S0BUF, and a stop bit sets the flag RB80 in the SFR S0CON. In mode 1, either internal baud rate generator or timer 1 can be used to specify the desired baud rate.



Fig. 8-3: Transmit mode 1 for Serial 0

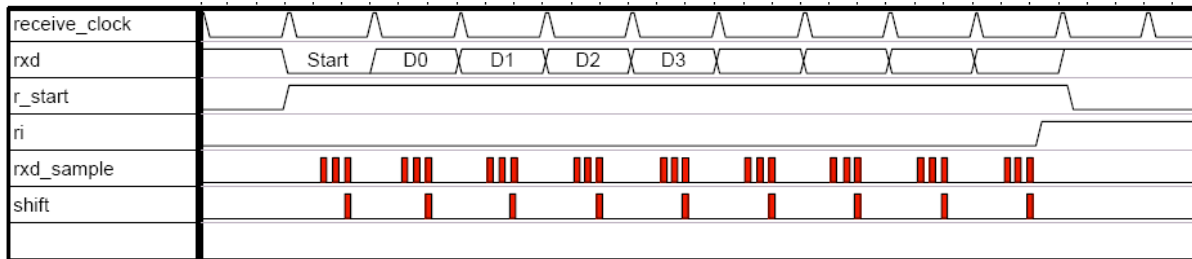

Fig. 8-4: Receive mode 1 for Serial 0

8.1.3 Mode 2

This mode is similar to Mode 1, but with two differences. The baud rate is fixed at 1/32 (SMOD=1) or 1/64 (SMOD=0) of oscillator frequency, and 11 bits are transmitted or received: a start bit (0), 8 data bits (LSB first), a programmable Bit 9, and a stop bit (1). Bit 9 can be used to control the parity of the serial interface: at transmission, bit TB8 in S0CON is output as Bit 9, and at receive, Bit 9 affects RB8 in SFR S0CON.

8.1.4 Mode 3

The only difference between Mode 2 and Mode 3 is that: in Mode 3, either internal baud rate generator or timer 1 can be use to specify baud rate.

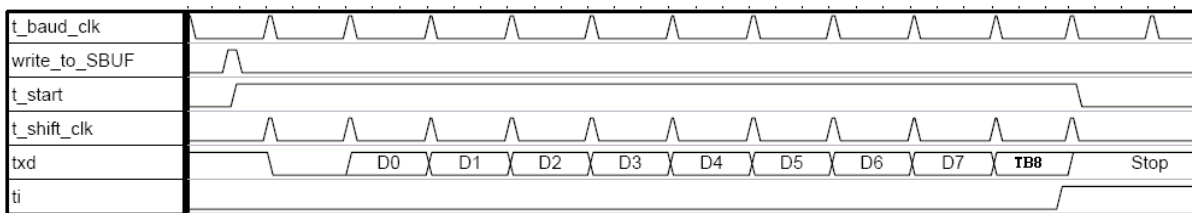

Fig. 8-5: Transmit modes 2 and 3 for Serial 0

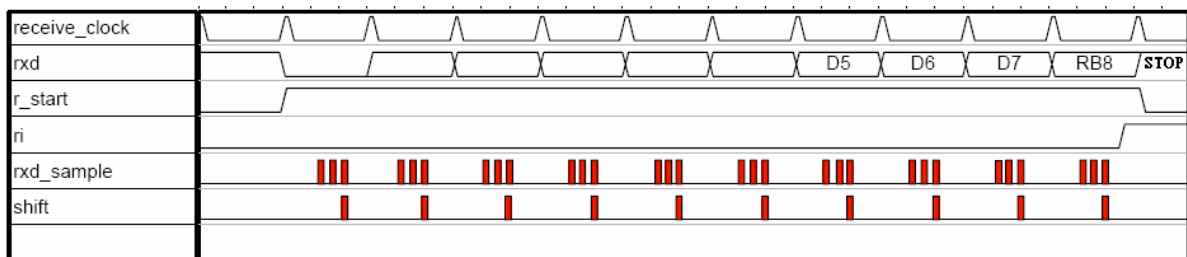

Fig. 8-6: Receive modes 2 and 3 for Serial 0



8.2 Multiprocessor communication of Serial Interface 0

The feature of receiving 9 bits in Modes 2 and 3 of Serial Interface 0 can be used for multiprocessor communication. In this case, the slave processors have bit SM20 in S0CON. When the master processor outputs slave's address, it sets the Bit 9 to 1, causing a serial port receive interrupt in all the slaves. The slave processors compare the received byte with their network address. If matched, the addressed slave will clear SM20 and receive the rest of the message, while other slaves will leave SM20 bit unaffected and ignore this message. After addressing the slave, the host will output the rest of the message with the Bit 9 set to 0, so no serial port receive interrupt will be generated in unselected slaves.

8.3 Baud rate generator

8.3.1 Serial interface 0 modes 1 and 3

(a) When BRGS = 0 (in SFR AUX):

8.3.1.1 T1PS[1:0] = 00

$$\text{Baud Rate} = \frac{2^{\text{SMOD}} \times F_{\text{OSC}}}{32 \times 12 \times (256 - \text{TH1})}$$

8.3.1.2 T1PS[1:0] = 01

$$\text{Baud Rate} = \frac{2^{\text{SMOD}} \times F_{\text{OSC}}}{32 \times (256 - \text{TH1})}$$

8.3.1.3 T1PS[1:0] = 10

$$\text{Baud Rate} = \frac{2^{\text{SMOD}} \times F_{\text{OSC}}}{32 \times 96 \times (256 - \text{TH1})}$$

(b) When BRGS = 1 (in SFR AUX):

8.3.1.4 S0RELPS[1:0] = 00

$$\text{Baud Rate} = \frac{2^{\text{SMOD}} \times F_{\text{OSC}}}{64 \times (2^{10} - \text{S0REL})}$$

8.3.1.5 S0RELPS[1:0] = 01

$$\text{Baud Rate} = \frac{2^{\text{SMOD}} \times F_{\text{OSC}}}{32 \times (2^{10} - \text{S0REL})}$$

8.3.1.6 S0RELPS[1:0] = 10

$$\text{Baud Rate} = \frac{2^{\text{SMOD}} \times F_{\text{OSC}}}{16 \times (2^{10} - \text{S0REL})}$$

8.3.1.7 S0RELPS[1:0] = 11

$$\text{Baud Rate} = \frac{2^{\text{SMOD}} \times F_{\text{OSC}}}{8 \times (2^{10} - \text{S0REL})}$$



9 Watchdog timer

The Watch Dog Timer (WDT) is an 8-bit free-running counter that generate reset signal if the counter overflows. The WDT is useful for systems which are susceptible to noise, power glitches, or electronics discharge which causing software dead loop or runaway. The WDT function can help user software recover from abnormal software condition. The WDT is different from Timer0, Timer1 and Timer2 of general 8052. To prevent a WDT reset can be done by software periodically clearing the WDT counter. User should check WDTF bit of WDTC register whenever un-predicted reset happened. After an external reset the watchdog timer is disabled and all registers are set to zeros.

The watchdog timer has a free running on-chip RC oscillator (250KHz). The WDT will keep on running even after the system clock has been turned off (for example, in sleep mode). During normal operation or sleep mode, a WDT time-out (if enabled) will cause the MCU to reset. The WDT can be enabled or disabled any time during the normal mode. Please refer the WDTE bit of WDTC register. The default WDT time-out period is approximately 16.38ms (WDTM [3:0] = 0100b).

The WDT has selectable divider input for the time base source clock. To select the divider input, the setting of bit3 ~ bit0 (WDTM [3:0]) of Watch Dog Timer Control Register (WDTC) should be set accordingly.

$$WDTCLK = \frac{250\text{KHz}}{2^{\text{WDTM}}}$$

$$\text{Watchdog reset time} = \frac{256}{WDTCLK}$$

Table 9.1 WDT time-out period

WDTM [3:0]	Divider (250 KHz RC oscillator in)	Time period @ 250KHz
0000	1	1.02ms
0001	2	2.05ms
0010	4	4.10ms
0011	8	8.19ms
0100	16	16.38ms (default)
0101	32	32.77ms
0110	64	65.54ms
0111	128	131.07ms
1000	256	262.14ms
1001	512	524.29ms
1010	1024	1.05s
1011	2048	2.10s
1100	4096	4.19s
1101	8192	8.39s
1110	16384	16.78s
1111	32768	33.55s



Mnemonic: TAKEY							Address: F7H	
7	6	5	4	3	2	1	0	Reset
TAKEY [7:0]								00H

Watchdog timer control register (WDTC) is read-only by default; software must write three specific values 55H, AAH and 5AH sequentially to the TAKEY register to enable the WDTC write attribute. That is:

```
MOV TAKEY, #55H
MOV TAKEY, #AAH
MOV TAKEY, #5AH
```

Mnemonic: WDTC						Address: B6H		
7	6	5	4	3	2	1	0	Reset
-	-	WDTE	-	WDTM [3:0]				04H

WDTE: Control bit used to enable Watchdog timer.

The WDTE bit can be used only if WDTEN is "0". If the WDTEN bit is "0", then WDT can be disabled / enabled by the WDTE bit.

0: Disable WDT.

1: Enable WDT.

The WDTE bit is not used if WDTEN is "1". That is, if the WDTEN bit is "1", WDT is always disabled no matter what the WDTE bit status is. The WDTE bit can be read and written.

WDTM [3:0]: WDT clock source divider bit. Please see table 9.1 to reference the WDT time-out period.

Mnemonic: WDTK							Address: B7H	
7	6	5	4	3	2	1	0	Reset
WDTK[7:0]								00H

WDTK: Watchdog timer refresh key.

A programmer must write 0x55 into WDTK register, and then the watchdog timer will be cleared to zero.

For example, if enable WDT and select time-out reset period is 327.68ms.

First, programming the information block OP3 bit7 WDTEN to "0".

Secondly,

```
MOV TAKEY, #55H
```

```
MOV TAKEY, #AAH
```

```
MOV TAKEY, #5AH
```

```
MOV WDTC, #28H
```

```
; enable WDTC write attribute.
```

```
; Set WDTM [3:0] = 1000b. Set WDTE =1 to enable WDT
```

```
; function.
```

```
.
```

```
.
```

```
MOV WDTK, #55H
```

```
; Clear WDT timer to 0.
```

Mnemonic: RSTS								Address: A1H
7	6	5	4	3	2	1	0	Reset
-	-	-	PDRF	WDTF	SWRF	LVRF	PORF	00H

WDTF: Watchdog timer reset flag.

When MCU is reset by watchdog, WDTF flag will be set to one by hardware. This flag clear by software or external reset or power on reset.



10 Interrupt

The SM59R16G6 provides 10 interrupt sources with four priority levels. Each source has its own request flag(s) located in a special function register. Each interrupt requested by the corresponding flag could individually be enabled or disabled by the enable bits in SFR's IEN0, IEN1.

When the interrupt occurs, the engine will vector to the predetermined address as shown in Table 10.1. Once interrupt service has begun, it can be interrupted only by a higher priority interrupt. The interrupt service is terminated by a return from instruction RETI. When an RETI is performed, the processor will return to the instruction that would have been next when interrupt occurred.

When the interrupt condition occurs, the processor will also indicate this by setting a flag bit. This bit is set regardless of whether the interrupt is enabled or disabled. Each interrupt flag is sampled once per machine cycle, and then samples are polled by hardware. If the sample indicates a pending interrupt when the interrupt is enabled, then interrupt request flag is set. On the next instruction cycle the interrupt will be acknowledged by hardware forcing an LCALL to appropriate vector address.

Interrupt response will require a varying amount of time depending on the state of microcontroller when the interrupt occurs. If microcontroller is performing an interrupt service with equal or greater priority, the new interrupt will not be invoked. In other cases, the response time depends on current instruction. The fastest possible response to an interrupt is 7 machine cycles. This includes one machine cycle for detecting the interrupt and six cycles for perform the LCALL.

Table 10-1: Interrupt vectors

Interrupt Request Flags	Interrupt Vector Address	Interrupt Number *(use Keil C Tool)
IE0 – External interrupt 0	0003H	0
TF0 – Timer 0 interrupt	000BH	1
IE1 – External interrupt 1	0013H	2
TF1 – Timer 1 interrupt	001BH	3
RI0/TI0 – Serial channel 0 interrupt	0023H	4
TF2/EXF2 – Timer 2 interrupt	002BH	5
PWMIF – PWM interrupt	0043H	8
SPIIF – SPI interrupt	004BH	9
LVIIIF – Low Voltage Interrupt	0063H	12
IICIF – IIC interrupt	006BH	13

*See Keil C about C51 User's Guide about Interrupt Function description



Mnemonic	Description	Direct	Bit 7	Bit 6	Bit 5	Bit 4	Bit 3	Bit 2	Bit 1	Bit 0	RESET
Interrupt											
IEN0	Interrupt Enable 0 register	A8H	EA	-	ET2	ES0	ET1	EX1	ET0	EX0	00H
IEN1	Interrupt Enable 1 register	B8H	EXEN2	-	IEIIC	IELVI	-	-	IESPI	IEPWM	00H
IRCON	Interrupt request register	C0H	EXF2	TF2	IICIF	LVIIF	-	-	SPIIF	PWMIF	00H
IP0	Interrupt priority level 0	A9H	-	-	IP0.5	IP0.4	IP0.3	IP0.2	IP0.1	IP0.0	00H
IP1	Interrupt priority level 1	B9H	-	-	IP1.5	IP1.4	IP1.3	IP1.2	IP1.1	IP1.0	00H

Interrupt Enable 0 register(IEN0)

Mnemonic: IEN0								Address: A8H	
7	6	5	4	3	2	1	0	Reset	
EA	-	ET2	ES0	ET1	EX1	ET0	EX0	00H	

- EA: EA=0 – Disable all interrupt.
EA=1 – Enable all interrupt.
- ET2: ET2=0 – Disable Timer 2 overflow or external reload interrupt.
ET2=1 – Enable Timer 2 overflow or external reload interrupt.
- ES0: ES0=0 – Disable Serial channel 0 interrupt.
ES0=1 – Enable Serial channel 0 interrupt.
- ET1: ET1=0 – Disable Timer 1 overflow interrupt.
ET1=1 – Enable Timer 1 overflow interrupt.
- EX1: EX1=0 – Disable external interrupt 1.
EX1=1 – Enable external interrupt 1.
- ET0: ET0=0 – Disable Timer 0 overflow interrupt.
ET0=1 – Enable Timer 0 overflow interrupt.
- EX0: EX0=0 – Disable external interrupt 0.
EX0=1 – Enable external interrupt 0.

Interrupt Enable 1 register(IEN1)

Mnemonic: IEN1								Address: B8H	
7	6	5	4	3	2	1	0	Reset	
EXEN2	-	IEIIC	IELVI	-	-	IESPI	IEPWM	00H	

- EXEN2: Timer 2 reload interrupt enable.
EXEN2 = 0 – Disable Timer 2 external reload interrupt.
EXEN2 = 1 – Enable Timer 2 external reload interrupt.
- IEIIC: IIC interrupt enable.
IEIICS = 0 – Disable IIC interrupt.
IEIICS = 1 – Enable IIC interrupt.
- IELVI: LVI interrupt enable.
IELVI = 0 – Disable LVI interrupt.
IELVI = 1 – Enable LVI interrupt.
- IESPI: SPI interrupt enable.
IESPI = 0 – Disable SPI interrupt.
IESPI = 1 – Enable SPI interrupt.
- IEPWM: PWM interrupt enable.
IEPWM = 0 – Disable PWM interrupt.

Specifications subject to change without notice contact your sales representatives for the most recent information.



IEPWM = 1 – Enable PWM interrupt.

Interrupt request register(IRCON)

Mnemonic: IRCON							Address: C0H	
7	6	5	4	3	2	1	0	Reset
EXF2	TF2	IICIF	LVIIIF	-	-	SPIIF	PWMIF	00H

EXF2: Timer 2 external reloads flag. Must be cleared by software.

TF2: Timer 2 overflows flag. Must be cleared by software.

IICIF: IIC interrupt flag.

LVIIIF: LVI interrupt flag.

SPIIF: SPI interrupt flag.

PWMIF: PWM interrupt flag. Must be cleared by software.

10.1 Priority level structure

All interrupt sources are combined in groups:

Table 10-2: Priority level groups

Groups	
External interrupt 0	PWM interrupt
Timer 0 interrupt	SPI interrupt
External interrupt 1	-
Timer 1 interrupt	-
Serial channel 0 interrupt	LVI interrupt
Timer 2 interrupt	IIC interrupt

Each group of interrupt sources can be programmed individually to one of four priority levels by setting or clearing one bit in the special function register IP0 and one in IP1. If requests of the same priority level will be received simultaneously, an internal polling sequence determines which request is serviced first.

Mnemonic: IP0							Address: A9H	
7	6	5	4	3	2	1	0	Reset
-	-	IP0.5	IP0.4	IP0.3	IP0.2	IP0.1	IP0.0	00H

Mnemonic: IP1							Address: B9H	
7	6	5	4	3	2	1	0	Reset
-	-	IP1.5	IP1.4	IP1.3	IP1.2	IP1.1	IP1.0	00H

Table 10-3: Priority levels

IP1.x	IP0.x	Priority Level
0	0	Level0 (lowest)
0	1	Level1
1	0	Level2
1	1	Level3 (highest)



Table 10-4: Groups of priority

Bit	Group	
IP1.0, IP0.0	External interrupt 0	PWM interrupt
IP1.1, IP0.1	Timer 0 interrupt	SPI interrupt
IP1.2, IP0.2	External interrupt 1	-
IP1.3, IP0.3	Timer 1 interrupt	-
IP1.4, IP0.4	Serial channel 0 interrupt	LVI interrupt
IP1.5, IP0.5	Timer 2 interrupt	IIC interrupt

Table 10-5: Polling sequence

Interrupt source	Sequence
External interrupt 0	 Polling sequence
PWM interrupt	
Timer 0 interrupt	
SPI interrupt	
External interrupt 1	
Timer 1 interrupt	
Serial channel 0 interrupt	
LVI interrupt	
Timer 2 interrupt	
IIC interrupt	



11 Power Management Unit

Power management unit serves two power management modes, IDLE and STOP, for the users to do power saving function.

Mnemonic: PCON							Address: 87H	
7	6	5	4	3	2	1	0	Reset
SMOD	-	-	-	-	-	STOP	IDLE	40H

STOP: Stop mode control bit. Setting this bit turning on the Stop Mode.
Stop bit is always read as 0

IDLE: Idle mode control bit. Setting this bit turning on the Idle Mode.
Idle bit is always read as 0

11.1 Idle mode

Setting the IDLE bit of PCON register invokes the IDLE mode. The IDLE mode leaves internal clocks and peripherals running. Power consumption drops because the CPU is not active. The CPU can exit the IDLE state with any interrupts or a reset.

11.2 Stop mode

Setting the STOP bit of PCON register invokes the STOP mode. All internal clocking in this mode is turn off. The CPU will exit this state from a no-clocked interrupt (external INT0/1, LVI) or a reset (WDT and LVR) condition. Internally generated interrupts (timer, serial port ...) have no effect on stop mode since they require clocking activity.



12 Pulse Width Modulation (PWM)

SM59R16G6 provides four-channel PWM outputs.
The interrupt vector is 43H.

Mnemonic	Description	Direct	Bit 7	Bit 6	Bit 5	Bit 4	Bit 3	Bit 2	Bit 1	Bit 0	RESET
AUX	Auxiliary register	91H	BRGS	-	P4SPI	P1UR	P4IIC	-	P2PWM	DPS	00H
PWMC	PWM Control register	B5H	PWMCS[2:0]			-	PWM3EN	PWM2EN	PWM1EN	PWM0EN	00H
PWMD0H	PWM 0 Data register high byte	BCH	PWMP0	-	-	-	-	-	PWMD0[9:8]		00H
PWMD0L	PWM 0 Data register low byte	BDH	PWMD0[7:0]								00H
PWMD1H	PWM 1 Data register high byte	BEH	PWMP1	-	-	-	-	-	PWMD1[9:8]		00H
PWMD1L	PWM 1 Data register low byte	BFH	PWMD1[7:0]								00H
PWMD2H	PWM 2 Data register high byte	B1H	PWMP2	-	-	-	-	-	PWMD2[9:8]		00H
PWMD2L	PWM 2 Data register low byte	B2H	PWMD2[7:0]								00H
PWMD3H	PWM 3 Data register high byte	B3H	PWMP3	-	-	-	-	-	PWMD3[9:8]		00H
PWMD3L	PWM 3 Data register low byte	B4H	PWMD3[7:0]								00H
PWMMDH	PWM Max Data register high byte	CEH	-	-	-	-	-	-	PWMMD[9:8]		00H
PWMDL	PWM Max Data register low byte	CFH	PWMMD[7:0]								FFH

Mnemonic: AUX

Address: 91H

7	6	5	4	3	2	1	0	Reset
BRGS	-	P4SPI	P1UR	P4IIC	-	P2PWM	DPS	00H

P2PWM : P2PWM = 0 – PWM function on P4.

P2PWM = 1 – PWM function on P2.

Mnemonic: PWMC

Address: B5H

7	6	5	4	3	2	1	0	Reset
PWMCS[2:0]			-	PWM3EN	PWM2EN	PWM1EN	PWM0EN	00H

PWMCS[2:0]: PWM clock select.

PWMCS [2:0]	Mode
000	Fosc
001	Fosc/2
010	Fosc/4
011	Fosc/6
100	Fosc/8
101	Fosc/12
110	Timer 0 overflow
111	Timer 0 external input (P3.4/T0)

Specifications subject to change without notice contact your sales representatives for the most recent information.



PWM3EN: PWM channel 3 enable control bit.
PWM3EN = 1 – PWM channel 3 enable.
PWM3EN = 0 – PWM channel 3 disable.

PWM2EN: PWM channel 2 enable control bit.
PWM2EN = 1 – PWM channel 2 enable.
PWM2EN = 0 – PWM channel 2 disable.

PWM1EN: PWM channel 1 enable control bit.
PWM1EN = 1 – PWM channel 1 enable.
PWM1EN = 0 – PWM channel 1 disable.

PWM0EN: PWM 0 enable control bit.
PWM0EN = 1 – PWM channel 0 enable.
PWM0EN = 0 – PWM channel 0 disable.

Mnemonic: PWMD0H							Address: BCH	
7	6	5	4	3	2	1	0	Reset
PWMP0	-	-	-	-	-	PWMD0[9:8]		00H

Mnemonic: PWMD0L							Address: BDH	
7	6	5	4	3	2	1	0	Reset
PWMD0[7:0]								00H

PWMP0: PWM channel 0 idle polarity select.
“0” – PWM channel 0 will idle low.
“1” – PWM channel 0 will idle high.

PWMD0[9:0]: PWM channel 0 data register.

Mnemonic: PWMD1H							Address: BEH	
7	6	5	4	3	2	1	0	Reset
PWMP1	-	-	-	-	-	PWMD1[9:8]		00H

Mnemonic: PWMD1L							Address: BFH	
7	6	5	4	3	2	1	0	Reset
PWMD1[7:0]								00H

PWMP1: PWM channel 1 idle polarity select.
“0” – PWM channel 1 will idle low.
“1” – PWM channel 1 will idle high.

PWMD1[9:0]: PWM channel 1 data register.

Mnemonic: PWMD2H							Address: B1H	
7	6	5	4	3	2	1	0	Reset
PWMP2	-	-	-	-	-	PWMD2[9:8]		00H

Mnemonic: PWMD2L							Address: B2H	
7	6	5	4	3	2	1	0	Reset
PWMD2[7:0]								00H

PWMP2: PWM channel 2 idle polarity select.
“0” – PWM channel 2 will idle low.
“1” – PWM channel 2 will idle high.

PWMD2[9:0]: PWM channel 2 data register.



Mnemonic: PWMD3H							Address: B3H	
7	6	5	4	3	2	1	0	Reset
PWMP3	-	-	-	-	-	PWMD3[9:8]		00H

Mnemonic: PWMD3L							Address: B4H	
7	6	5	4	3	2	1	0	Reset
PWMD3[7:0]								00H

PWMP3: PWM channel 3 idle polarity select.

“0” – PWM channel 3 will idle low.

“1” – PWM channel 3 will idle high.

PWMD3[9:0]: PWM channel 3 data register.

Mnemonic: PWMMDH							Address: CEH	
7	6	5	4	3	2	1	0	Reset
-	-	-	-	-	-	PWMMD[9:8]		00H

Mnemonic: PWMDL							Address: CFH	
7	6	5	4	3	2	1	0	Reset
PWMMD[7:0]								FFH

PWMMD[9:0]: PWM Max Data register.

PWM count from 0000H to PWMMD[9:0]. When PWM count data equal PWMMD[9:0] is overflow.

PWMPx = 0 & PWMDx = 00H

PWMPx _____ Low _____

PWMPx = 0 & PWMDx ≠ 00H

PWMPx _____

PWMPx = 1 & PWMDx = 00H

PWMPx _____ High _____

PWMPx = 1 & PWMDx ≠ 00H

PWMPx _____

$$\text{PWM period} = \frac{\text{PWMMD} + 1}{\text{PWM clock}}$$

$$\text{Leader pulse} = \frac{\text{PWMDx}}{\text{PWM clock}}$$



13 IIC function

The IIC module uses the SCL (clock) and the SDA (data) line to communicate with external IIC interface. Its speed can be selected to 400Kbps (maximum) by software setting the IICBR [2:0] control bit. The IIC module provided 2 interrupts (RXIF, TXIF). It will generate START, repeated START and STOP signals automatically in master mode and can detects START, repeated START and STOP signals in slave mode. The maximum communication length and the number of devices that can be connected are limited by a maximum bus capacitance of 400pF.

The interrupt vector is 6BH.

Mnemonic	Description	Direct	Bit 7	Bit 6	Bit 5	Bit 4	Bit 3	Bit 2	Bit 1	Bit 0	RESET
IIC function											
AUX	Auxiliary register	91H	BRGS	-	P4SPI	P1UR	P4IIC	-	P2PWM	DPS	00H
IICCTL	IIC control register	F9H	IICEN		MSS	MAS	RStart	IICBR[2:0]			04H
IICS	IIC status register	F8H	MStart	RXIF	TXIF	RDR	TDR	RXAK	TXAK	RW	00H
IICA1	IIC Address 1 register	FAH	IICA1[7:1]							MATCH1 or RW1	A0H
IICA2	IIC Address 2 register	FBH	IICA2[7:1]							MATCH2 or RW2	60H
IICRWD	IIC Read/Write register	FCH	IICRWD[7:0]								00H
IICS2	IIC status2 register	FDH	-	-	-	-	AB_EN	BF_EN	AB_F	BF	00H

Mnemonic: AUX

Address: 91H

7	6	5	4	3	2	1	0	Reset
BRGS	-	P4SPI	P1UR	P4IIC	-	P2PWM	DPS	00H

P4IIC: P4IIC = 0 – IIC function on P1.
P4IIC = 1 – IIC function on P4.

Mnemonic: IICCTL

Address: F9H

7	6	5	4	3	2	1	0	Reset
IICEN		MSS	MAS	RStart	IICBR[2:0]			04H

IICEN: Enable IIC module

IICEN = 1 is Enable
IICEN = 0 is Disable.

MSS: Master or slave mode select.

MSS = 1 is master mode.
MSS = 0 is slave mode.

*The software must set this bit before setting others register.

MAS: Master address select (master mode only)

MAS = 0 is to use IICA1.
MAS = 1 is to use IICA2.

RStart: Re-start control bit (master mode only)

When this bit is set, the module will generate a start condition to the SDA and SCL lines (after current ACK) and send out the calling address which is stored in the IICA1 or IICA2(selected by MAS control bit).When module is finished to send out address, this bit will be cleared by hardware.

IICBR[2:0]: Baud rate selection (master mode only), where Fosc is the external crystal or oscillator frequency. The default is Fosc/512 for users' convenience.

IICBR[2:0]	Baud rate
000	Fosc/32
001	Fosc/64
010	Fosc/128
011	Fosc/256
100	Fosc/512
101	Fosc/1024
110	Fosc/2048
111	Fosc/4096

Mnemonic: IICS							Address: F8H	
7	6	5	4	3	2	1	0	Reset
MStart	RxIF	TxIF	RDR	TDR	RxAk	TxAk	RW	00H

MStart: Master Start control bit. (Master mode only)

If set the MStart bit, the module will generate a start condition to the SDA and SCL lines and send out the calling address which is stored in the IICA1 or IICA2 (selected by MAS control bit). When software cleared this bit, the module will generate a stop condition to the SDA and SCL.

RxIF: The data Receive Interrupt Flag (RXIF) is set after the IICRWD (IIC Read Write Data Buffer) is loaded with a newly receive data.

TxIF: The data Transmit Interrupt Flag (TXIF) is set when the data of the IICRWD (IIC Read Write Data Buffer) is downloaded to the shift register.

RDR: The MCU must clear this bit after it gets the data from IICRWD. The IIC module is able to write new data into IICRWD only when this bit is cleared.

TDR: When MCU finish writing data to IICRWD, the MCU needs to set this bit to '1' to inform the IIC module to send the data in the IICRWD. After IIC module finishes sending the data from IICRWD, this bit will be cleared automatically.

RxAk: The Acknowledge Status indicate bit. When clear, it means an acknowledge signal has been received after the complete 8 bits data transmit on the bus.

TxAk: The Acknowledge status transmit bit. When received complete 8 bits data, this bit will set (NoAck) or clear (Ack) and transmit to master to indicate the receive status. Actually, it is sent as the 9th bit in one byte transmission as show in Fig. 14-1.

RW: The slave mode read (received) or wrote (transmit) on the IIC bus. When this bit is clear, the slave module received data on the IIC bus (SDA).(Slave mode only)

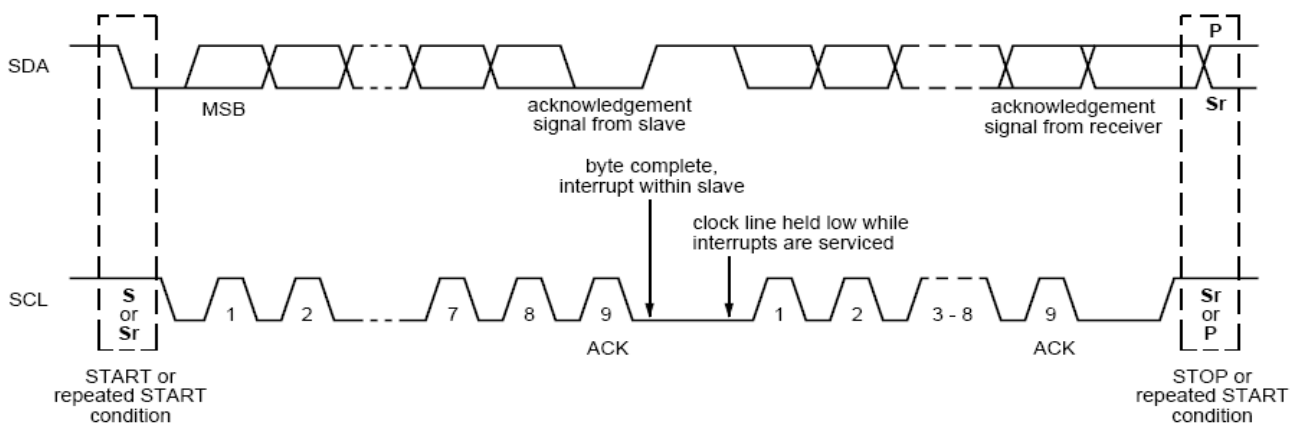

Fig. 13-1: Acknowledgement bit in the 9th bit of a byte transmission



Mnemonic: IICA1							Address: FAH	
7	6	5	4	3	2	1	0	Reset
IICA1[7:1]							Match1 or RW1	A0H
R/W							R or R/W	

Slave mode:

IICA1[7:1]: IIC Address registers

This is the first 7-bit address for this slave module. It will be checked when an address (from master) is received

Match1: When IICA1 matches with the received address from the master side, this bit will set to 1 by hardware. When IIC bus gets first data, this bit will clear automatically.

Master mode:

IICA1[7:1]: IIC Address registers

This 7-bit address indicate the slave with which it want to communicate.

RW1: This bit will be sent out as RW of the slave side if the module has set the MStart or RStart bit. It appears at the 8th bit after the IIC address as shown in Fig. 14-2. It is used to tell the salve the direction of the following communication. If it is 1, the module is in master receive mode. If 0, the module is in master transmit mode.

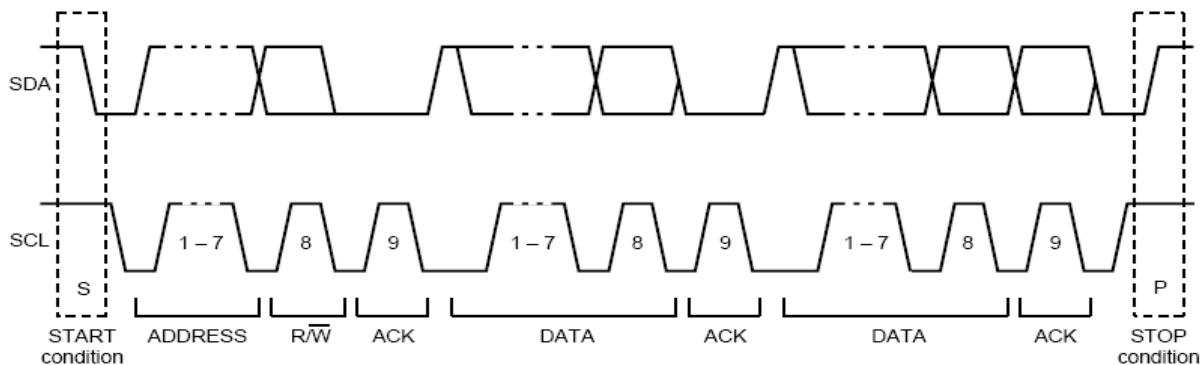

Fig. 13-2: RW bit in the 8th bit after IIC address

Mnemonic: IICA2							Address: FBH	
7	6	5	4	3	2	1	0	Reset
IICA2[7:1]							Match2 or RW2	60H
R/W							R or R/W	

Slave mode:

IICA2[7:1]: IIC Address registers

This is the second 7-bit address for this slave module.

It will be checked when an address (from master) is received

Match2: When IICA2 matches with the received address from the master side, this bit will set to 1 by hardware. When IIC bus gets first data, this bit will clear automatically.

Master mode:

IICA2[7:1]: IIC Address registers

This 7-bit address indicate the slave with which it want to communicate.

RW2: This bit will be sent out as RW of the slave side if the module has set the MStart or RStart bit. It is used to tell the salve the direction of the following communication. If it is 1, the module is in master receive mode. If 0, the module is in master transmit mode.



Mnemonic: IICRWD							Address: FCh	
7	6	5	4	3	2	1	0	Reset
IICRWD[7:0]								00H

IICRWD[7:0]: IIC read write data buffer.

In receiving (read) mode, the received byte is stored here.

In transmitting mode, the byte to be shifted out through SDA stays here.

Mnemonic: IICS2							Address: FDH	
7	6	5	4	3	2	1	0	Reset
-	-	-	-	AB_EN	BF_EN	AB_F	BF	00H

AB_EN: Arbitration lost enable bit. (Master mode only)

If set AB_EN bit, the hardware will check arbitration lost. Once arbitration lost occurred, hardware will return to IDLE state. If this bit is cleared, hardware will not care arbitration lost condition. Set this bit when multi-master and slave connection. Clear this bit when single master to single slave.

BF_EN: Bus busy enable bit. (Master mode only)

If set BF_EN bit, hardware will not generate a start condition to bus until BF=0. Clear this bit will always generate a start condition to bus when MStart is set. Set this bit when multi-master and slave connection. Clear this bit when single master to single slave.

AB_F: Arbitration lost bit. (Master mode only)

In multi-master condition, when send out data bit "1" but return back "0", bus arbitration lost occurred and this bit will be set. Software need to clear this bit and check until BF=0 to resend data again.

BF: Bus busy bit. (Master mode only)

If detect scl=0 or sda=0 or bus start, this bit will be set. If detect stop and a period passed (about 4.7us), this bit will be cleared. This bit can be cleared by software to return ready state.



14 SPI function

Serial Peripheral Interface (SPI) is a synchronous protocol that allows a master device to initiate communication with slave devices.
The interrupt vector is 4BH.

There are 4 signals used in SPI, they are

SPI_MOSI: data output in the master mode, data input in the slave mode,
SPI_MISO: data input in the master mode, data output in the master mode,
SPI_SCK: clock output form the master, the above data are synchronous to this signal
SPI_SS: input in the slave mode.

This slave device detects this signal to judge if it is selected by the master.
In the master mode, it can select the desired slave device by any IO with value = 0. Fig. 14-1 is an example showing the relation of the 4 signals between master and slaves.

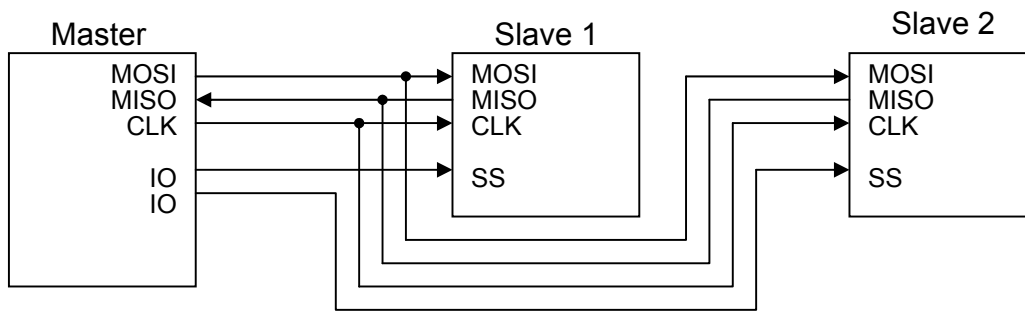

Fig. 14-1: SPI signals between master and slave devices

There is only one channel SPI interface. The SPI SFRs are shown as below:

SPI	Description	Direct	Bit 7	Bit 6	Bit 5	Bit 4	Bit 3	Bit 2	Bit 1	Bit 0	RESET
SPI function											
AUX	Auxiliary register	91H	BRGS	-	P4SPI	P1UR	P4IIC	-	P2PWM	DPS	00H
SPIC1	SPI control register 1	F1H	SPIEN	SPIMSS	SPISSP	SPICKP	SPICKE	SPIBR[2:0]			08H
SPIC2	SPI control register 2	F2H	SPIFD	TBC[2:0]			SPIRST	RBC[2:0]			00H
SPIS	SPI status register	F5H	SPIRF	SPIMLS	SPIOV	SPITXIF	SPITDR	SPIRXIF	SPIRDR	SPIRS	40H
SPITXD	SPI transmit data buffer	F3H	SPITXD[7:0]								00H
SPIRXD	SPI receive data buffer	F4H	SPIRXD[7:0]								00H

Mnemonic: AUX

Address: 91H

7	6	5	4	3	2	1	0	Reset
BRGS	-	P4SPI	P1UR	P4IIC	-	P2PWM	DPS	00H

P4SPI: P4SPI = 0 – SPI function on P1.
P4SPI = 1 – SPI function on P4.



Mnemonic: SPIC1							Address: F1H	
7	6	5	4	3	2	1	0	Reset
SPIEN	SPIMSS	SPISSP	SPICKP	SPICKE	SPIBR[2:0]		08H	

- SPIEN: Enable SPI module. "1" is Enable. "0" is Disable.
- SPIMSS: Master or Slave mode Select
"1" is Master mode.
"0" is Slave mode.
- SPISSP: Slave Select (SS) active polarity (slave mode used only)
"1" - high active.
"0" - low active.
- SPICKP: Clock idle polarity (master mode used only)

"1" – SPI_SCK high during idle. Ex :



"0" – SPI_SCK low during idle. Ex :



- SPICKE: Clock sample edge select.
"1" – data latch in rising edge
"0" – data latch in falling edge.

* To ensure the data latch stability, SM59R16G6 generate the output data as given in the following example, the other side can latch the stable data no matter in rising or falling edge.

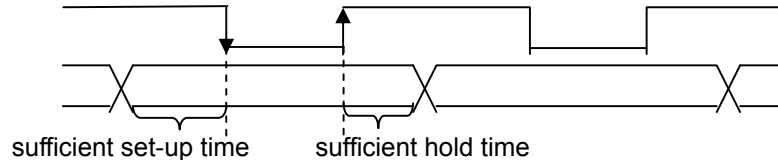

SPIBR[2:0]: SPI baud rate select (master mode used only), here Fosc is the external crystal or oscillator frequency :

SPIBR[2:0]	Baud rate
0:0:0	Fosc/4
0:0:1	Fosc/8
0:1:0	Fosc/16
0:1:1	Fosc/32
1:0:0	Fosc/64
1:0:1	Fosc/128
1:1:0	Fosc/256
1:1:1	Fosc/512

Mnemonic: SPIC2							Address: F2H	
7	6	5	4	3	2	1	0	Reset
SPIFD	TBC[2:0]			SPIRST	RBC[2:0]		00H	

- SPIFD: Full-duplex mode enable.
"1" : enable full-duplex mode.
"0" : disable full-duplex mode.
- When it is set, the TBC[2:0] and RBC[2:0] will be reset and keep to zero, i.e., only 8-bit communication is allowed in the full-duplex mode. When the master device transmits data to the slave device via the MOSI line, the slave device responds sends data back to the master device



via the MISO line. This implies that full-duplex transmission with both out-data and in-data are synchronized with the same clock SCK as shown below.

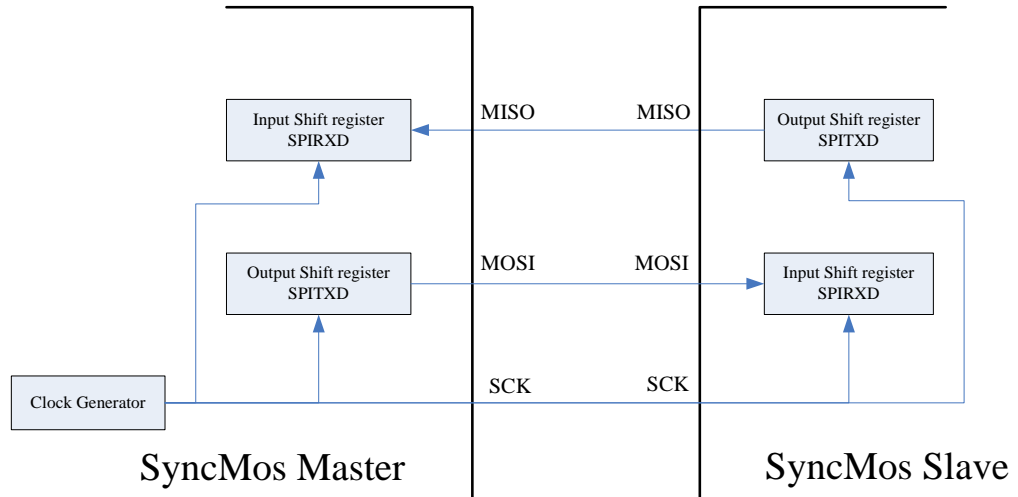

TBC[2:0]: SPI transmitter bit counter, here 1-8 bits are allowed except for the full-duplex mode

TBC[2:0]	Bit counter
0:0:0	8 bits output
0:0:1	1 bit output
0:1:0	2 bits output
0:1:1	3 bits output
1:0:0	4 bits output
1:0:1	5 bits output
1:1:0	6 bits output
1:1:1	7 bits output

SPIRST: SPI Restart. (Slave mode used only)

SPIRST = 0 is disable.
SPI transmit/receive data when SS active.
SPIRST = 1 is enable.
SPI transmit/receive new data when SS restart.

RBC[2:0]: SPI receiver bit counter, here 1-8 bits are allowed except for the full-duplex mode

RBC[2:0]	Bit counter
0:0:0	8 bits input
0:0:1	1 bit input
0:1:0	2 bits input
0:1:1	3 bits input
1:0:0	4 bits input
1:0:1	5 bits input
1:1:0	6 bits input
1:1:1	7 bits input

Mnemonic: SPIS

Address: F5H

7	6	5	4	3	2	1	0	Reset
SPIRF	SPIMLS	SPIOV	SPITXIF	SPITDR	SPIRXIF	SPIRDR	SPIRS	40H

SPIRF: SPI SS/CS Release Flag.

This bit is set when SS/CS release & SPIRST as '1'.

SPIMLS: MSB or LSB first output /input Select.



“1” is MSB first output/input.

“0” is LSB first output/input.

SPIOV: Overflow flag.

When SPIRDR is set and next data already into shift register, this flag will be set.

It is clear by hardware, when SPIRDR is cleared.

SPITXIF: Transmit Interrupt Flag.

This bit is set when the data of the SPITXD register is downloaded to the shift register.

SPITDR: Transmit Data Ready.

When MCU finish writing data to SPITXD register, the MCU needs to set this bit to ‘1’ to inform the SPI module to send the data. After SPI module finishes sending the data from SPITXD, this bit will be cleared automatically.

SPIRXIF: Receive Interrupt Flag.

This bit is set after the SPIRXD is loaded with a newly receive data.

SPIRDR: Receive Data Ready.

The MCU must clear this bit after it gets the data from SPIRXD register. The SPI module is able to write new data into SPIRXD only when this bit is cleared.

SPIRS: Receive Start.

This bit set to “1” to inform the SPI module to receive the data into SPIRXD register.

Mnemonic: SPITXD							Address: F3H	
7	6	5	4	3	2	1	0	Reset
SPITXD[7:0]								00H

SPITXD[7:0]: Transmit data buffer.

Mnemonic: SPIRXD							Address: F4H	
7	6	5	4	3	2	1	0	Reset
SPIRXD[7:0]								00H

SPIRXD[7:0]: Receive data buffer.

P.S. MISO pin must be floating when SS or CS no-active in slave mode.



15 LVI – Low Voltage Interrupt

The interrupt vector 63H.

Mnemonic: LVC								Address: E6H	
7	6	5	4	3	2	1	0	Reset	
LVI_EN	-	LVR_EN	LVSIF	-	-	-	LVIS	20H	

LVI_EN: Low voltage interrupt function enable bit.

LVI_EN = 0 : disable low voltage detect function.

LVI_EN = 1 : enable low voltage detect function.

LVR_EN External low voltage reset function enable bit.

LVR_EN = 0 - disable external low voltage reset function.

LVR_EN = 1 - enable external low voltage reset function.

LVSIF Low Voltage Status Flag

1:the VDD voltage under LVI voltage

0:the VDD voltage above LVI voltage

LVIS: Low Voltage Interrupt level Selection:

0 :The level of voltage is Low-level

1 :The level of voltage is Hi-level

Hi-level :

Symbol	Parameter	Min	Typ	Max	Units
V _{LVI}	Low Voltage Interrupt Voltage Level	3.4	3.7	4.0	V
V _{LVR}	Low Voltage Reset Voltage Level	3.2	3.5	3.8	V

Notes: The VLVI always above VLVR about 0.2V.

Low-level :

Symbol	Parameter	Min	Typ	Max	Units
V _{LVI}	Low Voltage Interrupt Voltage Level	2.1	2.3	2.5	V
V _{LVR}	Low Voltage Reset Voltage Level	1.9	2.1	2.3	V

Notes: The VLVI always above VLVR about 0.2V.



16 In-System Programming (Internal ISP)

The SM59R16G6 can generate flash control signal by internal hardware circuit. Users utilize flash control register, flash address register and flash data register to perform the ISP function without removing the SM59R16G6 from the system. The SM59R16G6 provides internal flash control signals which can do flash program/chip erase/page erase/protect functions. User need to design and use any kind of interface which SM59R16G6 can input data. User then utilize ISP service program to perform the flash program/chip erase/page erase/protect functions.

16.1 ISP service program

The ISP service program is a user developed firmware program which resides in the ISP service program space. After user developed the ISP service program, user then determine the size of the ISP service program. User need to program the ISP service program in the SM59R16G6 for the ISP purpose.

The ISP service programs were developed by user so that it should includes any features which relates to the flash memory programming function as well as communication protocol between SM59R16G6 and host device which output data to the SM59R16G6. For example, if user utilize UART interface to receive/transmit data between SM59R16G6 and host device, the ISP service program should include baud rate, checksum or parity check or any error-checking mechanism to avoid data transmission error.

The ISP service program can be initiated under SM59R16G6 active or idle mode. It can not be initiated under power down mode.

16.2 Lock Bit (N)

The Lock Bit N has two functions: one is for service program size configuration and the other is to lock the ISP service program space from flash erase function.

The ISP service program space address range \$F000 to \$FFFF. It can be divided as blocks of N*256 byte. (N=0 to 16). When N=0 means no ISP function, all of 64K byte flash memory can be used as program memory. When N=1 means ISP service program occupies 256 byte while the rest of 63.75K byte flash memory can be used as program memory. The maximum ISP service program allowed is 4K byte when N=16. Under such configuration, the usable program memory space is 60K byte.

After N determined, SM59R16G6 will reserve the ISP service program space downward from the top of the program address \$FFFF. The start address of the ISP service program located at \$Fx00 while x is an even number, depending on the lock bit N. As shown in Table 19-1.

The lock bit N function is different from the flash protect function. The flash erase function can erase all of the flash memory except for the locked ISP service program space. If the flash not has been protected, the content of ISP service program still can be read. If the flash has been protected, the overall content of flash program memory space including ISP service program space can not be read.

Specifications subject to change without notice contact your sales representatives for the most recent information.



Table 16.1 ISP code area.

N	ISP service program address
0	No ISP service program
1	256 bytes (\$FF00h ~ \$FFFFh)
2	512 bytes (\$FE00h ~ \$FFFFh)
3	768 bytes (\$FD00h ~ \$FFFFh)
4	1.0 K bytes (\$FC00h ~ \$FFFFh)
5	1.25 K bytes (\$FB00h ~ \$FFFFh)
6	1.5 K bytes (\$FA00h ~ \$FFFFh)
7	1.75 K bytes (\$F900h ~ \$FFFFh)
8	2.0 K bytes (\$F800h ~ \$FFFFh)
9	2.25 K bytes (\$F700h ~ \$FFFFh)
10	2.5 K bytes (\$F600h ~ \$FFFFh)
11	2.75 K bytes (\$F500h ~ \$FFFFh)
12	3.0 K bytes (\$F400h ~ \$FFFFh)
13	3.25 K bytes (\$F300h ~ \$FFFFh)
14	3.5 K bytes (\$F200h ~ \$FFFFh)
15	3.75 K bytes (\$F100h ~ \$FFFFh)
16	4.0 K bytes (\$F000h ~ \$FFFFh)

ISP service program configurable in N*256 byte (N= 0 ~ 16)

16.3 Program the ISP Service Program

After Lock Bit N is set and ISP service program been programmed, the ISP service program memory will be protected (locked) automatically. The lock bit N has its own program/erase timing. It is different from the flash memory program/erase timing so the locked ISP service program can not be erased by flash erase function. If user needs to erase the locked ISP service program, he can do it by writer only. User can not change ISP service program when SM59R16G6 was in system.

16.4 Initiate ISP Service Program

To initiate the ISP service program is to load the program counter (PC) with start address of ISP service program and execute it. There are four ways to do so:

- (1) Blank reset. Hardware reset with first flash address blank (\$0000~\$FFFH) will load the PC with start address of ISP service program. The hardware reset includes Internal (power on reset) and external pad reset.
- (2) Execute jump instruction can load the start address of the ISP service program to PC.
- (3) Enters ISP service program by hardware setting. User can force SM59R16G6 enter ISP service program by setting P2.6, P2.7 “active low” or P4.3 “ active low” during hardware reset period. The hardware reset includes Internal (power on reset) and external pad reset. In application system design, user should take care of the setting of P2.6, P2.7 or P4.3 at reset period to prevent SM59R16G6 from entering ISP service program.



- (4) Enter's ISP service program by hardware setting, the port3.0 will be detected the two clock signals during hardware reset period. The hardware reset includes Internal (power on reset) and external pad reset. And detect 2 clock signals after hardware reset.

During hardware reset period, the hardware will detect the status of P2.6/P2.7/P4.3/P3.0. If they meet one of above conditions, chip will switch to ISP mode automatically. After ISP service program executed, user need to reset the SM59R16G6, either by hardware reset or by WDT, or jump to the address \$0000 to re-start the firmware program.

There are 8 kinds of entry mechanisms for user different applications. This entry method will select on the writer or ISP.

- (1) First Address Blank. i.e. \$0000 = 0xFF. And triggered by Internal reset signal.
- (2) First Address Blank. i.e. \$0000 = 0xFF. And triggered by PAD reset signal.
- (3) P2.6 = 0 & P2.7 = 0. And triggered by Internal reset signal.
- (4) P2.6 = 0 & P2.7 = 0. And triggered by PAD reset signal.
- (5) P4.3 = 0. And triggered by Internal reset signal.
- (6) P4.3 = 0. And triggered by PAD reset signal.
- (7) P3.0 input 2 clocks. And triggered by Internal reset signal.
- (8) P3.0 input 2 clocks. And triggered by PAD reset signal.

16.5 ISP register – TAKEY, IFCON, ISPF AH, ISPFAL, ISPF D and ISPF C

Mnemonic	Description	Direct	Bit 7	Bit 6	Bit 5	Bit 4	Bit 3	Bit 2	Bit 1	Bit 0	RESET
ISP function											
TAKEY	Time Access Key register	F7H	TAKEY [7:0]								00H
IFCON	Interface Control register	8FH	ITS	CDPR	-	-	ALEC[1:0]	EMEN	ISPE		00H
ISPF AH	ISP Flash Address - High register	E1H	ISPF AH [7:0]								FFH
ISPFAL	ISP Flash Address - Low register	E2H	ISPFAL [7:0]								FFH
ISPF D	ISP Flash Data register	E3H	ISPF D [7:0]								FFH
ISPF C	ISP Flash Control register	E4H	EMF1	EMF2	EMF3	EMF4	-	ISPF.2	ISPF.1	ISPF.0	00H

Mnemonic: TAKEY

Address: F7H

7	6	5	4	3	2	1	0	Reset
TAKEY [7:0]								00H

ISP enable bit (ISPE) is read-only by default, software must write three specific values 55H, AAH and 5AH sequentially to the TAKEY register to enable the ISPE bit write attribute. That is:

```
MOV TAKEY, #55H
```



MOV TAKEY, #AAH
MOV TAKEY, #5AH

Mnemonic: IFCON							Address: 8FH	
7	6	5	4	3	2	1	0	Reset
ITS	CDPR	-	-	ALEC[1:0]		EMEN	ISPE	00H

The bit 0 (ISPE) of IFCON is ISP enable bit. User can enable overall SM59R16G6 ISP function by setting ISPE bit to 1, to disable overall ISP function by set ISPE to 0. The function of ISPE behaves like a security key. User can disable overall ISP function to prevent software program be erased accidentally. ISP registers ISPF AH, ISPFAL, ISPF D and ISPF C are read-only by default. Software must be set ISPE bit to 1 to enable these 4 registers write attribute.

Mnemonic: ISPF AH								Address: E1H
7	6	5	4	3	2	1	0	Reset
ISPF AH7	ISPF AH6	ISPF AH5	ISPF AH4	ISPF AH3	ISPF AH2	ISPF AH1	ISPF AH0	FFH

ISPF AH [7:0]: Flash address-high for ISP function

Mnemonic: ISPF AL								Address: E2H
7	6	5	4	3	2	1	0	Reset
ISPF AL7	ISPF AL6	ISPF AL5	ISPF AL4	ISPF AL3	ISPF AL2	ISPF AL1	ISPF AL0	FFH

ISPF AL [7:0]: Flash address-Low for ISP function

The ISPF AH & ISPF AL provide the 16-bit flash memory address for ISP function. The flash memory address should not include the ISP service program space address. If the flash memory address indicated by ISPF AH & ISPF AL registers overlay with the ISP service program space address, the flash program/page erase of ISP function executed thereafter will have no effect.

Mnemonic: ISPF D								Address: E3H
7	6	5	4	3	2	1	0	Reset
ISPF D7	ISPF D6	ISPF D5	ISPF D4	ISPF D3	ISPF D2	ISPF D1	ISPF D0	FFH

ISPF D [7:0]: Flash data for ISP function.

The ISPF D provide the 8-bit data register for ISP function.

Mnemonic: ISPF C							Address: E4H	
7	6	5	4	3	2	1	0	Reset
EMF1	EMF2	EMF3	EMF4	-	ISPF [2]	ISPF [1]	ISPF [0]	00H

EMF1: Entry mechanism (1) flag, clear by reset. (Read only)

EMF2: Entry mechanism (2) flag, clear by reset. (Read only)

EMF3: Entry mechanism (3) flag, clear by reset. (Read only)

EMF4: Entry mechanism (4) flag, clear by reset. (Read only)

ISPF [2:0]: ISP function select bit.

ISPF [2:0]	ISP function
------------	--------------



000	Byte program
001	Chip protect
010	Page erase
011	Chip erase
100	Write option
101	Read option
110	Erase option
111	reserved

One page of flash memory is 256 byte

The Option function can access the Internal reset time select(description in section 1.4.1) 、 clock source select(description in section 1.5) 、 P4[4:6] pins function select(description in section 5) 、 WDTEN control bit(description in section 9) 、 or ISP entry mechanisms select(description in section 16) 。

When chip protected or no ISP service, option can only read.

The choice ISP function will start to execute once the software write data to ISPFC register.

To perform byte program/page erases ISP function, user need to specify flash address at first. When performing page erase function, SM59R16G6 will erase entire page which flash address indicated by ISPF AH & ISPF AL registers located within the page.

e.g. flash address: \$XYMN

page erase function will erase from \$XY00 to \$XYFF

To perform the chip erase ISP function, SM59R16G6 will erase all the flash program memory except the ISP service program space. To perform chip protect ISP function, the SM59R16G6 flash memory content will be read #00H.

e.g. ISP service program to do the byte program - to program #22H to the address \$1005H

```

MOV TAKEY, #55H
MOV TAKEY, #AAH
MOV TAKEY, #5AH      ; enable ISPE write attribute
MOV IFCON, #01H     ; enable SM59R16G6 ISP function
MOV ISPF AH, #10H   ; set flash address-high, 10H
MOV ISPF AL, #05H   ; set flash address-low, 05H
MOV ISPF D, #22H    ; set flash data to be programmed, data = 22H
MOV ISPF C, #00H    ; start to program #22H to the flash address $1005H

```



Operating Conditions

Symbol	Description	Min.	Typ.	Max.	Unit.	Remarks
TA	Operating temperature	-40	25	85	°C	Ambient temperature under bias
VDD	Supply voltage	2.7		5.5	V	

DC Characteristics

T_A = -40°C to 85°C, V_{CC} = 5.0V

Symbol	Parameter	Valid	Min	Max	Units	Conditions
VIL1	Input Low-voltage	Port 0,1,2,3,4,5	-0.5	0.8	V	V _{CC} =5V
VIL2	Input Low-voltage	RES, XTAL1	0	0.8	V	
VIH1	Input High-voltage	Port 0,1,2,3,4,5	2.0	V _{CC} + 0.5	V	
VIH2	Input High-voltage	RES, XTAL1	70%V _{CC}	V _{CC} + 0.5	V	
VOL	Output Low-voltage	Port 0,1,2,3,4,5		0.4	V	IOL=4.9mA V _{CC} =5V
VOH1	Output High-voltage using Strong Pull-up ⁽¹⁾	Port 0,1,2,3,4,5	90% V _{CC}		V	IOH= -4.6mA
VOH2	Output High-voltage using Weak Pull-up ⁽²⁾	Port 0,1,2,3,4,5	2.4		V	IOH= -250uA
			75% V _{CC}		V	IOH= -162uA
			90% V _{CC}		V	IOH= -73uA
IIL	Logic 0 Input Current	Port 0,1,2,3,4,5		-75	uA	Vin= 0.45V
ITL	Logical Transition Current	Port 0,1,2,3,4,5		-650	uA	Vin= 2.0V
ILI	Input Leakage Current	Port 0,1,2,3,4,5		±10	uA	0.45V<Vin<V _{CC}
RRST	Reset Pull-down Resistor	RES	50	300	kΩ	
CIO	Pin Capacitance			10	pF	Freq= 1MHz, Ta= 25°C
ICC	Power Supply Current	VDD		12	mA	Active mode, 12MHz V _{CC} =5V 25 °C
				11	mA	Idle mode, 12MHz V _{CC} =5V 25 °C
				5	uA	Power down mode V _{CC} =5V 25 °C

- Notes :
1. Port in Push-Pull Output Mode
 2. Port in Quasi-Bidirectional Mode



$T_A = -40^{\circ}\text{C}$ to 85°C , $V_{CC} = 3.0\text{V}$

Symbol	Parameter	Valid	Min	Max	Units	Conditions
VIL1	Input Low-voltage	Port 0,1,2,3,4,5	-0.5	0.8	V	$V_{CC}=3.0\text{V}$
VIL2	Input Low-voltage	RES, XTAL1	0	0.8	V	
VIH1	Input High-voltage	Port 0,1,2,3,4,5	2.0	$V_{CC} + 0.5$	V	
VIH2	Input High-voltage	RES, XTAL1	$70\%V_{CC}$	$V_{CC} + 0.5$	V	
VOL	Output Low-voltage	Port 0,1,2,3,4,5		0.4	V	$I_{OL}=3.2\text{mA}$ $V_{CC}=3.0\text{V}$
VOH1	Output High-voltage using Strong Pull-up ⁽¹⁾	Port 0,1,2,3,4,5	$90\% V_{CC}$		V	$I_{OH}= -2.3\text{mA}$
VOH2	Output High-voltage using Weak Pull-up ⁽²⁾	Port 0,1,2,3,4,5	2.4		V	$I_{OH}= -77\mu\text{A}$
			$90\% V_{CC}$		V	$I_{OH}= -33\mu\text{A}$
IIL	Logic 0 Input Current	Port 0,1,2,3,4,5		-75	μA	$V_{in} = 0.45\text{V}$
ITL	Logical Transition Current	Port 0,1,2,3,4,5		-650	μA	$V_{in}=1.5\text{V}$
ILI	Input Leakage Current	Port 0,1,2,3,4,5		± 10	μA	$0.45\text{V} < V_{in} < V_{CC}$
RRST	Reset Pull-down Resistor	RES	50	300	$\text{k}\Omega$	
CIO	Pin Capacitance			10	pF	Freq= 1MHz, $T_a = 25^{\circ}\text{C}$
ICC	Power Supply Current	VDD		11	mA	Active mode ,12MHz $V_{CC} = 3.0\text{V}$ 25°C
				10	mA	Idle mode, 12MHz $V_{CC} = 3.0\text{V}$ 25°C
				4	μA	Power down mode $V_{CC} = 3.0\text{V}$ 25°C

Notes : 1. Port in Push-Pull Output Mode
2. Port in Quasi-Bidirectional Mode